

CONSOLE  
RAYTHEON  
RC-11



If You Didn't Get This From My Site,  
Then It Was Stolen From...

[www.SteamPoweredRadio.Com](http://www.SteamPoweredRadio.Com)

INSTRUCTION MANUAL

FOR

AUDIO CONSOLE

MODEL RC-11



PARTS

Manufactured

By

RAYTHEON MANUFACTURING COMPANY

~~BROADCAST EQUIPMENT DIVISION~~

~~CHICAGO, ILLINOIS~~

S.O. 8613

*Equipment & Systems Division IB6-2*  
*100 River St,*  
*Waltham 54, Mass.*

## TABLE OF CONTENTS

<u>Title</u>	<u>Page</u>
Technical Summary.....	1
Electrical Characteristics (Main Unit).....	1
Physical Specifications (Main Unit).....	2
Electrical Specifications (Power Supply).....	2
Physical Specifications (Power Supply).....	2
General Description.....	3
Associated Equipment.....	3
Location of Console and Power Supply.....	3
Wiring to Console and Power Supply.....	3
Input Lines.....	4
Output Lines.....	4
Auxiliary Lines.....	4
Operating the Equipment.....	4
General Description.....	4
The Power Supply.....	5
Emergency Use of the Monitoring Amplifier as a Program Amplifier.....	5
Placing a Program On the Air.....	6
To Audition Studio C while Studio B is on the Air.....	6
To Place a Remote Line on the Air.....	6
To Listen to Remote Line No. 2 While Remote Line No. 1 is on the Air.....	6
To Talk Back to Studio B or C.....	6
To Talk to a Remote Line Point.....	6
Maintenance.....	7
Checking the Tubes, Switches and etc.....	7
Tube Socket Voltages.....	8
Replacement Parts List.....	9

## LIST OF ILLUSTRATIONS

Fig. 1. RC-11 Console Front.....	14
Fig. 2. RC-11 Console Wiring.....	15
Fig. 3. RC-11 Console Power Supply.....	16
Fig. 4. Studio Wiring Diagram.....	17
Fig. 5. RC-11 Console Block Diagram.....	18
Fig. 6. RC-11 Console Schematic Diagram.....	19
Fig. 7. RC-11 Console Power Supply Schematic.....	20
Fig. 8. Balanced "H" Pads 600/600 Ohms.....	21

RAYTHEON AUDIO CONSOLE  
MODEL RC-11

TECHNICAL SUMMARY

MAIN UNIT

Electrical Characteristics:

Input Impedance:

- (A) Five Microphone Inputs..... 30/50 or 200/250 ohm
- (B) Two Turntable Inputs..... 200/250 ohm  
(May be used as microphone pre-amplifiers if desired).
- (C) Nine Remote Line Inputs..... 600 ohm
- (D) Two Network Line Inputs..... 600 ohm

Output Impedance:

- (A) One Program Line..... 500/600 ohm ✓
- (B) Four Monitor Lines..... 500/600 ohm ✓

Gain: (Maximum at 1000 cycles)

- (A) Microphone Input to Line Output..... 108 db
- (B) Turntable Input to Line Output..... 108 db
- (C) Line Input to Line Output..... 57 db
- (D) Microphone Input to Monitor Output..... 107 db
- (E) Turntable Input to Monitor Output..... 107 db
- (F) Line Input to Monitor Output..... 56 db
- (G) Cue Input to Monitor Output..... 59 db

Line Output Level and Distortion:

- (A) Operating Level.....  $\pm 10$  to  $\pm 20$  db\*  
(Less than 1% rms harmonic distortion 50-15000 cycles).  
(1.5% distortion or less at 30 cycles).

Monitor Power Output and Distortion:

- (A) Levels to  $\pm 33$  db\*..... Less than 2% distortion 50-10000 cycles
- (B) Levels from  $\pm 33$  to 37 db\*..... Less than 4% distortion 50-10000 cycles

Line Output Noise Level (76 db gain,  $\pm 20$  db output)..... -60 db

Frequency Response:

- (A) Microphone Input to Line Output.....  $\pm 2$  db 30-15000 cycles
- (B) Microphone Input to Monitor Output.....  $\pm 2$  db 30-15000 cycles

Tubes:

- 11..... Raytheon 6J7 Metal
- 4..... Raytheon 6F6 Metal
- 2..... Raytheon 6SN7GT Glass

\*Zero db = 0.001 Watts



## GENERAL DESCRIPTION

The RC-11 Speech Input Console provides a modern, compact, flexible speech input unit mounted in a single all metal cabinet. Switching, mixing and amplifying of microphones, turntables, remote and network lines are accomplished by the RC-11 Console.

A hinged cabinet provides a housing for amplifiers, transformers, relays, terminal boards and etc. On a sloping front panel are mounted the mixing controls, lever action switching keys, VU switch and VU range switching controls, the VU meter, and master gain controls; see Figure 1.

Patented fasteners, readily releasing the top cover plate provide easy access to the tubes.

Plate form rubber mountings for the two inside chassis provide a flexible support and reduce shock and vibration to a minimum; see Figure 2. The pre-amplifier mounting plate (to the left) contains the seven pre-amplifiers. The amplifier mounting plate (to the right) contains the line amplifier and the monitoring or auditioning amplifier.

On the cabinet base are located the input and output terminal boards, the power terminal boards and the three relays for switching of the loudspeaker circuits.

A wall mounting or relay rack type mounting dual-power supply energizes the amplifying and relay switching equipment in the console; see Figure 3.

Associated Equipment. The choice of auxiliary operating equipment depends to a great extent upon studio design and applications of equipment. The number and type of microphones, the transcription turntables, the installation of signal lamps and loudspeakers are matters left to the discretion of the purchaser. Raytheon's engineering staff will be pleased to aid in the selection of auxiliary operating equipment.

Location of Console and Power Supply. Normally the console will be located on a desk in the control room. The power supply can be located on the wall, in a desk, or when removed from the wall case it can be mounted in a relay type rack or cabinet. Holes are provided in the base of the console for securely mounting the cabinet to the desk with mounting hardware. Mounting holes on 16 inch centers provide a secure fastening for the power supply case.

Wiring to Console and Power Supply. All wiring to the console is terminated at six terminal boards located on the inside base. Conduit or cable entrance holes are located in the base adjacent to each terminal board; see Figure 4. On the left of the base are located the "Microphone and Turntable" input terminals. To the left rear are located the "Lines In" terminals. To the right rear are located the power input terminals, and the power terminals for the connection of Studio warning light relay coils. To the right are located the "Lines Out" and "Loudspeaker" terminals. Cable entrances to the power supply are provided in both the base and the rear of the power supply case. Figure 4 represents a typical studio connection diagram. Wire

sizes and characteristics are noted in the wire table on the left side of this diagram. Note that low level lines, remote lines, power lines and loudspeaker lines are to be run in separate conduits. Shielding of incoming and outgoing lines should be brought in close to the termination points, tied together and grounded at the ground terminal of the power connection terminal board. Shielded lines should be drawn thru junction boxes and not spliced. If splicing is necessary, it is important that spliced portions of cable are adequately shielded.

Input Lines. The five microphone and two turntable input lines are normally terminated at 200/250 ohms impedance. To connect microphone inputs for 30/50 ohm operation remove the bus wire connecting terminals 3 and 4, and the bus wire connecting terminals 3 and 10 on transformers T1, T2 and etc. Join terminals 2 and 4 also 3 and 5. The line remains connected on terminals 2 and 5; see Figure 6.

The nine remote lines and two network lines terminate at 600 ohm repeater transformers.

Output Lines. "Lines Out" No. 1 terminates into a 6-12 db H pad of 600/600 ohms impedance located adjacent to the telephone line termination box. "Lines Out" No. 2 is in multiple with "Lines Out" No. 1 and can be used as a monitoring source by bridging high impedance head sets across its terminals; see Figure 4. Loudspeakers "A", "B", "C", and "D" operate into bridging-to-voice coil transformers. The input impedance of the bridging transformer should be 2000 ohms and the output of the transformer should match the impedance of the loudspeaker voice coil. Thordarson's T-60S48 transformer is suited for the above purpose.

All unterminated loudspeaker lines should be loaded at the terminal board with 2000 ohm, 2 watt resistors.

Figure 8 lists seven H pads that can be constructed of stock value 1 watt resistors. Each pad is composed of four series (A) resistors and two shunt (B) resistors. The junction point of the (B) resistors serves as a grounding point making the pad a balanced "H" structure.

Auxiliary Lines. Terminals No. 12 and 13 on the "Lines In" terminal board are provided for the connection of an external telephone handset jack.

Terminals No. 1, 2, and 3 on the warning light relay terminal board provide 6-9 V.D.C. for energizing the warning light relay coils. Raytheon Part No. 235-L-1 relay is recommended for this application.

#### OPERATING THE EQUIPMENT

General Description. Nine channel selector keys located above nine mixing channels provide selection of nine inputs to either the program or the monitoring amplifier input. Mixers 1 thru 5 are associated with the microphone circuits, mixers 6 and 7 with the turntable circuits and 8 and 9 with the remote and network lines; refer to block diagram, Figure 5.

Program switching keys 1 and 2 interlock with relay No. 1 to control "Loudspeaker B". Program switching keys 3 and 4 interlock with relay No. 2 to control "Loudspeaker C". Program switching key No. 5 interlocks with relay No. 3 to provide control of "Loudspeaker D".

Seven pre-amplifiers provide amplification (before mixing and switching) of the low level microphone and turntable inputs. Two repeater transformers with their associated terminating networks provide proper isolation for the remote and network lines.

Lever action type, remote line switching keys, 1 thru 9, allow lines 1 thru 9 to be switched to channel No. 8 for mixing when placed in the "Mix" position or a cue can be fed to lines 1 thru 9 when the switches are placed in "Cue" position. Network lines No. 1 or No. 2 terminate at Channel No. 9 for mixing and switching.

A "Program-Monitor" switch permits the operator to listen to the normal program amplifier output (thru a bridging network and the monitor amplifier) when the switch is in the "Pro" position. When the switch is in the center position the monitor amplifier is used for monitoring lines 1 to 9. When in the "Mon" position, auditioning of studio programs, transcriptions or incoming lines is served thru the monitor amplifier.

A "VU Switch" permits the connection of the visual monitoring circuit across the program line, the network lines, the remote lines or the monitor amplifier output line.

A "VU Control" provides a total of 24 db attenuation (in steps of 2 db) for the illuminated VU Meter. An "Off" position allows the Meter to be disconnected from the circuit.

The Program and Monitor Amplifier gain controls adjust the gains of their respective amplifiers for satisfactory operation.

The Power Supply. Refer to the Power Supply Schematic Diagram, Figure 7. The power supply consists of three units, the power supply for the program amplifier, the power supply for the monitor amplifier and the power supply for operation of the loudspeaker relays. On-Off switches and indicating lamps are located on the front panel. A pre-amplifier power change-over switch is located at the top center of the panel, permitting instantaneous connection of power to the pre-amplifiers in the advent of failure of either the program or the monitor amplifier power supply. Removal of a "snap-on" front panel gives immediate access to the 5U4G rectifier tubes and to the primary fuses.

Emergency Use of the Monitoring Amplifier as a Program Amplifier. In case of failure of the program amplifier or the program amplifier power supply, the monitor amplifier may be used for an emergency program amplifier.

An amplifier output switching key provides instantaneous selection of amplifier outputs to the "lines out" terminals. Loudspeaker circuits interlocked with this switch are disconnected when the switch is thrown to the



"Mon-Out" position. Placing of the output switching key in the "Mon-Out" position, the "Pro-Mon" key in the "Mon" position, the channel selector key in use to the "M" position, the VU switch to the "Mon" position and adjustment of gain to the required line level completes the transition of program changeover.

#### PLACING A PROGRAM ON THE AIR

To Place Microphone #1 in Studio B On the Air. Set all keys to center position, set "VU Switch" to "Pro", set "VU Range" to 20 (assuming there is a 12 db pad in the line to the transmitter and that it is desired to operate at 8 "VU" out), adjust "Program" gain control to 14, "Pro-Mon" switch to "Pro", amplifier output switching key to "Pro-Out", "Mic 1" switch to "P", bring up "Mic 1" fader so that voice peaks are indicated as 100 on the "VU" meter scale and adjust "Monitor" gain control so that control room loudspeaker output is at a satisfactory level for listening.

The same procedure is to be followed when placing any one of the microphone or turntable channels in operation. Setting of mixing controls and master gain controls will vary due to operational practice, output of microphones, line output operating level and etc. It is desirable to operate the microphone and turntable mixing controls near a maximum setting (minimum attenuation).

To Audition Studio C While Studio B is on the Air. Assume microphone No. 3 in Studio C is to be used. Place "Pro-Mon" switch in "Mon" position.

Place "Mic 3" switch in "M" position. Adjust "Mic 3" fader so that a desirable level is obtained from the control room loudspeaker.

To Place a Remote Line On the Air. Assume that a program on Remote Line No. 1 follows a broadcast from Studio B. Place "Remote Line Key 1" in "Cue" position. To place the remote broadcast "On the Air" flip "Remote Line Key 1" to the "Mix" position, the "RMT" switching key to the "P" position and adjust the "RMT" fader for correct operating level. Remote lines 1 thru 9 may be cued or placed on the air by following the same instructions as outlined above. Fader No. 9 has been reserved for use of the Network lines No. 1 or No. 2.

To Listen to Remote Line No. 2 While Remote Line No. 1 is On the Air. Place Remote Line Switch No. 2 in the "Cue" position. Place the "Pro-Mon" key in the center position. Adjust "Monitor" gain to the required listening level.

To Talk Back to Studio B or C. Assume a program is in progress in Studio C and we desire to talk to Studio B. Place the "Pro-Mon" key in the "Mon" position. Place the "Mic 5" switch in the "M" position. Adjust the gain with "Mic 5" fader and talk to Studio B with the announce microphone. To talk to Studio C with Studio B on the air the procedure is the same.

To Talk to a Remote Line Point. To talk to Remote No. 1 place remote key No. 1 in "Cue" position, place the "VU" switch in "RMT" position, the "VU Range" switch at 1 MW, the "Pro-Mon" key at "Mon", "Mic 5" switching

key at "M" and adjust "Mic 5" fader so that when speaking into the announce microphone, the "VU" meter reads to the 100 point on voice peaks.

### MAINTENANCE

#### Checking the Tubes, Switches, Attenuators, Relay Contacts and etc.

Lasting and efficient operation of the RC-11 Console depends a great deal on routine and thorough checking of the tubes and upon regular cleaning and, when necessary, lubricating of the varied moving and switching contacts. A complete set of selected tubes should be in stock for emergency use. Lever action keys are properly adjusted before shipment. Every day use of lever action keys, keeps the palladium contacts burnished. Contacts on keys that are seldom used can usually be cleaned by flipping the key from one locking position to another a number of times. Do not use grease solvents for cleaning lever action keys. Contacts should be burnished with a burnishing tool. Abrasive papers or cloths should not be used for cleaning contacts. Relay spring contacts should also be treated in the above manner.

Attenuators are protected from excess dust and grime by an aluminum cover. Removal of the cover, permits the switch blades and contacts to be cleaned. Do not use grease solvents such as carbontetrachloride for removing the dirty lubricant from the blades and contacts. Use a soft cloth and remove all the dirty lubricant. The Daven Company of Newark, N. J. supplies a lubricant, "Davenoil", which is satisfactory for re-lubricating the controls. White petrolatum thinned slightly with a high grade clock oil also makes a good lubricant.

MIKE 3 POSITION IS THE ~~Y~~  
TOWER" MIKE ~~ON THE HEAD SET~~. MIKE 3 SWITCH  
HAS BEEN CONNECTED TO OPERATE K2 RELAY WHICH  
HAS BEEN CONNECTED TO MUTE [CUT-OUT] MIKE 5,  
THE CONSOLE MIKE. *gaw 1/1/60*

TUBE SOCKET VOLTAGES

Voltages read with respect to ground (except filament voltages). 20,000 ohms/Volt Voltmeter. 115 Volts applied to power transformer primary. No signal input. Voltage readings may vary  $\pm 10\%$  from these shown.

SECTION	SYMBOL	TUBE TYPE	Ep		Ek		Esg	Ef
			Ep-1	Ep-2	Ek-1	Ek-2		
Pre-Amplifier	1V-1	6J7	70		2.2			5.9
	1V-2	6J7	70		2.2			5.9
	1V-3	6J7	70		2.2			5.9
	1V-4	6J7	70		2.2			5.9
	1V-5	6J7	70		2.2			5.9
	1V-6	6J7	70		2.2			5.9
	1V-7	6J7	70		2.2			5.9
Program Amp.	1V-8	6J7	84		2.7			6.0
	1V-9	6J7	189		2.3		88	6.0
	1V-10	6SN7	124	124	4.4	4.4		6.0
	1V-11	6F6	300		23.5			6.0
	1V-12	6F6	300		23.5			6.0
Monitor Amp.	1V-13	6J7	85		2.7			5.9
	1V-14	6J7	188		2.2		87	5.9
	1V-15	6SN7	126	126	4.5	4.5		5.9
	1V-16	6F6	300		19.5		275	5.9
	1V-17	6F6	300		19.5		275	5.9

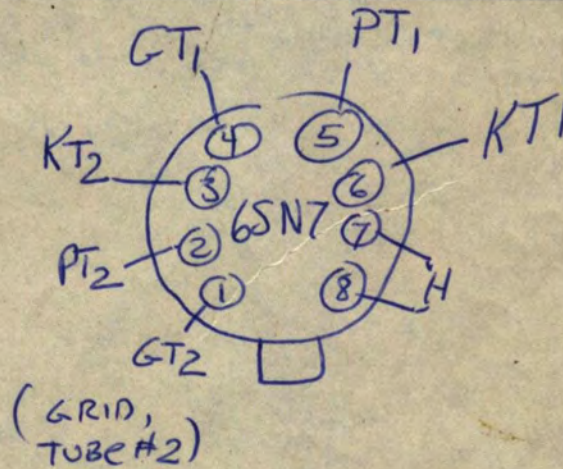
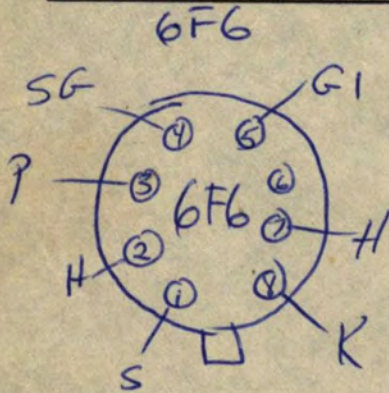

## REPLACEMENT PARTS LIST

SYMBOL NUMBER	NO. REQ	DESCRIPTION	SUPPLIER	RAYTHEON PART NO.
C-1,2,4,6,7,8,9,12,13	9	Condenser: 0.1 Mfd. 600 V. DCW, paper tubular #TP418	Mallory	50-L-10A
C-3,5	2	Condenser: 15 Mfd. $\pm 50\%$ V. DCW, electrolytic condenser #FP143	Mallory	50-L-21B
C-10,11	2	Condenser: 0.01 Mfd. $\pm 10\%$ 300 V. DCW, Type 339	Micamold	50-L-22A
C-14,15,16	3	Condenser: 4 Mfd. 600 V. DCW. oil filled type TLA 6040	Cornell-Dub.	50-L-19A
	4	Knob	John Mack & Sons	166-V-21A
F-1	1	Fuse: 3 AMP Type 3AG	Bussman	
I-1	1	Pilot Bulb: 6-8V, Type R-44	Raytheon	177-L-2A
J-1	1	Plug: #61M10	Amphenol	219-L-1A
L-1,2	2	Choke: 10 H. 100 Ma. #M10584	Raytheon	65-L-15A
M-1	1	Meter: 0-1 Ma. DC Model 301 rectangular flush bakelite case 3 1/8" x 3" calib. for 3/16" Al panel	Weston	187-U-40
R-1,29	2	Potentiometer: 500 ohm, 4 watt No. M500 P	Mallory	244-L-8A
R-2	1	Resistor: 180 ohm $\pm 10\%$ 1W. insulated carbon, Type GB	Allen Bradley	237-L-200
R-3,4	2	Resistor: 470,000 ohm $\pm 10\%$ $\frac{1}{2}$ W. insulated carbon, Type EB	Allen Bradley	237-L-168
R-5,13,14	3	Resistor: 100,000 ohm $\pm 10\%$ 1 W. insulated carbon, Type GB	Allen Bradley	237-L-233
R-6	1	Resistor: 22,000 ohm $\pm 10\%$ 1 W. insulated carbon, Type GB	Allen Bradley	237-L-550
R-7,8,9,10,11	5	Resistor: 2.2 Megohm $\pm 10\%$ $\frac{1}{2}$ W. insulated carbon, Type EB	Allen Bradley	237-L-176
R-15,16	2	Resistor: 560 ohm $\pm 10\%$ 1 W. insulated carbon, Type GB	Allen Bradley	237-L-206

## REPLACEMENT PARTS LIST

SYMBOL NUMBER	NO. REQ	DESCRIPTION	SUPPLIER	RAYTHEON PART NO.
R-17,18	2	Resistor: 56,000 ohm $\pm$ 10% 1 W. insulated carbon, Type GH	Allen Bradley	237-L-230
R-19,20	2	Resistor: 2400 ohm $\pm$ 5% 1 W. insulated carbon, Type GB	Allen Bradley	237-L-533
R-21,22, 27,28	4	Resistor: 220,000 ohm $\pm$ 10% $\frac{1}{2}$ W. insulated carbon, Type EB	Allen Bradley	237-L-164
R-23,24	2	Resistor: 82,000 ohm $\pm$ 10% 1 W. insulated carbon, Type GB	Allen Bradley	237-L-232
R-25	1	Resistor: 390,000 ohm $\pm$ 10% 1 W. insulated carbon, Type GB	Allen Bradley	237-L-240
R-26	1	Resistor: 390 ohm $\pm$ 10% 1 W. insulated carbon, Type GB	Allen Bradley	237-L-204
R-30,31	2	Resistor: 270,000 ohm $\pm$ 10% $\frac{1}{2}$ W. insulated carbon, Type EB	Allen Bradley	237-L-165
R-32,33	2	Resistor: 10,000 ohm $\pm$ 10% 1 W. insulated carbon, Type GB	Allen Bradley	237-L-221
R-34	1	Resistor: 30,000 ohm 10 W. Brown Devil	Ohmite	237-L-766B
R-35,36	2	Resistor: 150 ohm $\pm$ 10% $\frac{1}{2}$ W. insulated carbon, Type EB	Allen Bradley	237-L-126
R-38,39	2	Resistor: 270 ohm $\pm$ 10% $\frac{1}{2}$ W. insulated carbon, Type EB	Allen Bradley	237-L-129
R-37	1	Resistor: 820 ohm $\pm$ 10% $\frac{1}{2}$ W. insulated carbon, Type EB	Allen Bradley	237-L-135
R-40	1	Resistor: 360 ohm $\pm$ 5% $\frac{1}{2}$ W. insulated carbon, Type EB	Allen Bradley	237-L-368
R-41,42	2	Resistor: 470 ohm $\pm$ 10% 2 W. insulated carbon, Type HB	Allen Bradley	237-L-278
R-43	1	Resistor: 4900 ohm (select from 4700 ohm $\frac{1}{2}$ W. $\pm$ 5% stock resistors)	Allen Bradley	237-L-395
R-44	1	Resistor: 52,405 ohm (select from 51,000 $\frac{1}{2}$ W. $\pm$ 5% stock resistors)	Allen Bradley	237-L-420

RC-11 CONSOLE  
REPLACEMENT PARTS LIST

SYMBOL NO. Prefix 1	NO. REQ.	DESCRIPTION	SUPPLIER	RAYTHEON PART NO.
C-1 thru 7 C-16,19,26, 28,31,38	13	Condenser, 50 mfd $-10\%/200\%$ 50 V. DCW. #TC-39	Mallory	
C-8	1	Condenser, Type FP-149, 80 mfd 450 V. DCW.	Mallory	50-A-141A
C-9 thru 15 C-18,22,24, 25,27,30,34, 36,37,39	17	Condenser, 0.1 mfd, $\pm 25\%$ 600 V. DCW. #TP418	Mallory	50-L-10A
C-17A, C-17B, C-29A, C-29B	2	Condenser, 20-20 mfd $-10\%/50\%$ 450 V. DCW. #FP234	Mallory	50-L-26A
C-20,32	2	Condenser, 0.5 mfd. $\pm 25\%$ 600 V. DCW. #TP432	Mallory	
C-23,35	2	Condenser, .005 mfd $\pm 25\%$ 600 V. DCW. #TP408	Mallory	
C-40,41	2	Condenser, 15 mfd $-10\%/50\%$ 450 V. DCW. #FP143	Mallory	50-L-21B
C-42,43,44	3	Condenser, 25 mfd 25 V. DCW. C.D. Beaver Type #BR 252A	Cornell- Dub.	
C-45	1	Condenser, .0002 mfd Mica, 500 V. DCW. Type 5W5T2	Cornell- Dub.	
K-1,2,3	3	Relay, 6 V. Coil, (make, break contacts) D-24451	C. P. Clare	235-L-1A
M-1	1	Meter, VU Meter, Model 862 illuminated, Calibrated for mounting on 1/16" Steel. Type 30B scale, furnished with nuts and washers	Weston	187-V-1A
R-1,2,3,4, 5,6,7,58,78	9	Resistor, 1500 ohm $\pm 10\%$ $\frac{1}{2}$ W. Insulated Carbon, Type EB	Allen Bradley	237-L-138
R-8,59,64, 79,84	5	Resistor, 10,000 ohm $\pm 10\%$ 1 W. Insulated Carbon, Type GB	Allen Bradley	237-L-221
R-9,10,11,12, 13,14,15,60, 70,71,80,90, 91	13	Resistor, 100,000 ohm, $\pm 10\%$ 1 W. Insulated Carbon, Type GB	Allen Bradley	237-L-233

RC-11 CONSOLE  
REPLACEMENT PARTS LIST

SYMBOL Prefix 1	NO. REQ.	DESCRIPTION	SUPPLIER	RAYTHEON PART NO.
R-16 thru 24	9	Attenuator, 500/500 ladder Type #LA-350-F	Daven Co.	244-L-2A
R-25 thru R-51	27	Resistor, 470 ohm, $\pm 10\%$ $\frac{1}{2}$ W. Insulated Carbon, Type EB	Allen Bradley	237-L-132
R-52,53,117	3	Resistor, 22 ohm $\pm 10\%$ $\frac{1}{2}$ W. Insulated Carbon Type EB	Allen Bradley	237-L-116
R-54,55	2	Resistor, 2.5 ohms $\pm 5\%$ 5 W. Wire Wound	Lectrohm	
R-56,57,87	3	Resistor, 8200 ohm $\pm 10\%$ $\frac{1}{2}$ W. Insulated Carbon Type EB	Allen Bradley	237-L-147
R-61,81	2	Potentiometer, 250,000 ohm #CP-354-X	Daven Co.	244-L-4A
R-62,82	2	Resistor, 1000 ohm $\pm 10\%$ $\frac{1}{2}$ W. Insulated Carbon Type EB	Allen Bradley	237-L-136
R-63,83	2	Resistor, 390,000 $\pm 10\%$ $\frac{1}{2}$ W. Insulated Carbon, Type EB	Allen Bradley	237-L-167
R-65,85	2	Resistor, 47,000 ohm $\pm 10\%$ 1 W. Insulated Carbon, Type GB	Allen Bradley	237-L-229
R-66,86	2	Resistor, 470,000 ohm $\pm 10\%$ $\frac{1}{2}$ W. Insulated Carbon, Type EB	Allen Bradley	237-L-168
R-67	1	Resistor, 3900 ohm $\pm 10\%$ $\frac{1}{2}$ W. Insulated Carbon, Type EB	Allen Bradley	237-L-143
R-68,69,88,89	4	Resistor, 2200 ohm $\pm 10\%$ $\frac{1}{2}$ W. Insulated Carbon, Type EB	Allen Bradley	237-L-140
R-72,74,92,94	4	Resistor, 150,000 ohm $\pm 10\%$ $\frac{1}{2}$ W. Insulated Carbon, Type EB	Allen Bradley	237-L-162
R-73,93	2	Resistor, 18,000 ohm $\pm 10\%$ $\frac{1}{2}$ W. Insulated Carbon, Type EB	Allen Bradley	237-L-151
R-75	1	Resistor, 330 ohm $\pm 10\%$ 2 W. Insulated Carbon	Allen Bradley	237-L-276
R-76	1	Resistor, 330,000 ohm $\pm 10\%$ $\frac{1}{2}$ W. Insulated Carbon, Type EB	Allen Bradley	237-L-154

RC-11 CONSOLE  
REPLACEMENT PARTS LIST

SYMBOL NO. Prefix 1	NO. REQ.	DESCRIPTION	SUPPLIER	RAYTHEON PART NO.
R-77	1	Meter Multiplier, 7500/3900, 12 steps of 2 DB #T-994-2	Daven Co.	244-L-3A
R-95	1	Resistor, 270 ohm $\pm 10\%$ 2 W. Insulated Carbon	Allen Bradley	237-L-275
R-96	1	Resistor, 3300 ohm $\pm 10\%$ 1 W. Insulated Carbon, Type GB	Allen Bradley	237-L-215
R-97	1	Resistor, 47000 ohm $\pm 10\%$ $\frac{1}{2}$ W. Insulated Carbon, Type EB	Allen Bradley	237-L-156
R-98,99,100	3	Resistor, 2200 ohm $\pm 10\%$ 1 W. Insulated Carbon, Type GB	Allen Bradley	237-L-213
R-101,102	2	Resistor, 4700 ohm $\pm 10\%$ $\frac{1}{2}$ W. Insulated Carbon, Type EB	Allen Bradley	237-L-144
R-104,105	2	Resistor, 68 ohm $\pm 10\%$ $\frac{1}{2}$ W. Insulated Carbon, Type EB	Allen Bradley	237-L-122
R-106,107,108	3	Resistor, 180 ohm $\pm 10\%$ 1 W. Insulated Carbon, Type GB	Allen Bradley	237-L-200
R-109,103,110, 112,113,116	6	Resistor, 390 ohm $\pm 10\%$ $\frac{1}{2}$ W. Insulated Carbon, Type EB	Allen Bradley	237-L-131
R-111,114	2	Resistor, 100 ohm $\pm 10\%$ $\frac{1}{2}$ W. Insulated Carbon, Type EB	Allen Bradley	237-L-124
R-115	1	Resistor, 10,000/50 ohm H Pad, Type H950 60 DB Loss	Daven Co.	
S-1 thru 5	5	Switch, Lever action key, 11 contact, #A-24451	C. P. Clare	263-L-1A
S-6 thru 9	4	Switch, Lever action key, 8 contact, #B-24451	C. P. Clare	263-L-2A
S-10 thru 19	10	Switch, Lever action key, 6 contact, #C-24451	C. P. Clare	263-L-3A
S-20	1	Switch, Rotary 2 pole, 6 circuit, #1326-L	Mallory	263-U-4A
S-21	1	Switch, Lever action key, 24 contact, #A26561	C. P. Clare	263-L-13A



RC-11 CONSOLE  
REPLACEMENT PARTS LIST

SYMBOL NO. Prefix 1	NO. REQ.	DESCRIPTION	SUPPLIER	RAYTHEON PART NO.
S-22	1	Switch, Lever action key, 10 contact, #B26561	C. P. Clare	263-L-14A
T-1 thru 9	9	Transformer, Mic/line to 1 or 2 grids, #98453 RC-75 Case	U. T. C.	291-L-65A
T-10 thru 16	7	Transformer, 1 plate to line, #98454 RC-75 Case	U. T. C.	291-L-66A
T-17,18	2	Transformer, Line to line, #98455 RC-75 Case	U. T. C.	291-L-67A
T-19	1	Transformer, PP 6F6 Triode plates to line, #94193 RC-87 Case	U. T. C.	291-L-54A
T-20	1	Transformer, PP 6F6 Pentode Plate to line, #94194 RC-100 Case	U. T. C.	291-L-57A
TB-1,2,3	3	Terminal Board, 14 Contact, #14-ID	H.B.Jones	290-L-1A
TB-4	1	Terminal Board, 12 Contact, #12-ID	H.B.Jones	290-L-2A
TB-5,6,7	3	Terminal Board, 6 Contact, #6-141-3/4 W.	H.B.Jones	290-L-4A
V-1 thru 9 V-13,14	11	Tube, Type 6J7	Raytheon	
V-10,15	2	Tube, Type 6SN7GT	Raytheon	
V-11,12,16, 17	4	Tube, Type 6F6	Raytheon	
X-1 thru 17	17	Sockets, Mip-8 Black Bakelite or equivalent	Amphenol	256-L-2B

RC-11 CONSOLE  
POWER SUPPLY

SYMBOL NO. Prefix 2	NO. REQ.	DESCRIPTION	SUPPLIER	RAYTHEON PART NO.
C-1,2,3,4,5, 6	6	Condenser, 8 mfd -10/20% 600 V. DCW C.D. TJJ or similar	Cornell- Dub.	50-L-2A
C-7	1	Condenser, 1000 mfd 25 V. DCW. #HC2510	Mallory	50-L-9A
CR-1	1	Rectifier, Copper Sulphide, dry disc. #16R	Mallory	243-L-1A
F-1,2	2	Fuse, Type 4AG, 2 amp.	Littlefuse	
F-3	1	Fuse, Type 4AG, 1 amp.	Littlefuse	
I-1,2,3	3	Pilot Lamp, 6-8 V. Miniature Bayonet Base	Raytheon	177-L-2A
L-1,2,3,4	4	Reactor, 10 henry 100 Ma. DC. Raytheon Temporary #CAB-2, #M-10584	Raytheon	65-L-15A
R-1,2	2	Resistor, 30,000 ohm $\pm$ 10% 10 W. W.W.	Ohmite	237-L-1A
S-1,2,3	3	Switch, Toggle S.P.S.T. H&H #1012	Arrow Hart & Hegeman	263-L-8A
S-4	1	Switch, Rotary 3 circuit #1313L	Mallory	263-U-12A
T-1,2	2	Transformer, Power, 300 V. 100 Ma. DC. 5 V. at 3 A. 6.3 V. at 4.5 A. Raytheon Temp. #TAB-10 #M 10580	Raytheon	291-U-48A
T-3	1	Transformer, Step down, 10 V. at 1.5 A. Raytheon Temporary #TAB-9, #9497 RC-87	U. T. C.	291-L-60A
TB-1,2	2	Terminal Board, #7-141-YMS	H.B.Jones	290-L-25A
V-1,2	2	Tube, 5U4G	Raytheon	
X-1,2,3	3	Fuse Holder, Type HCM	Bussman	112-L-1A
X-4,5	2	Socket, Octal Bakelite, #MIP-8	Amphenol	256-L-2B
X-6,7,8	3	Pilot Assem. Drake #50	Drake	177-L-1A

2 1/8"

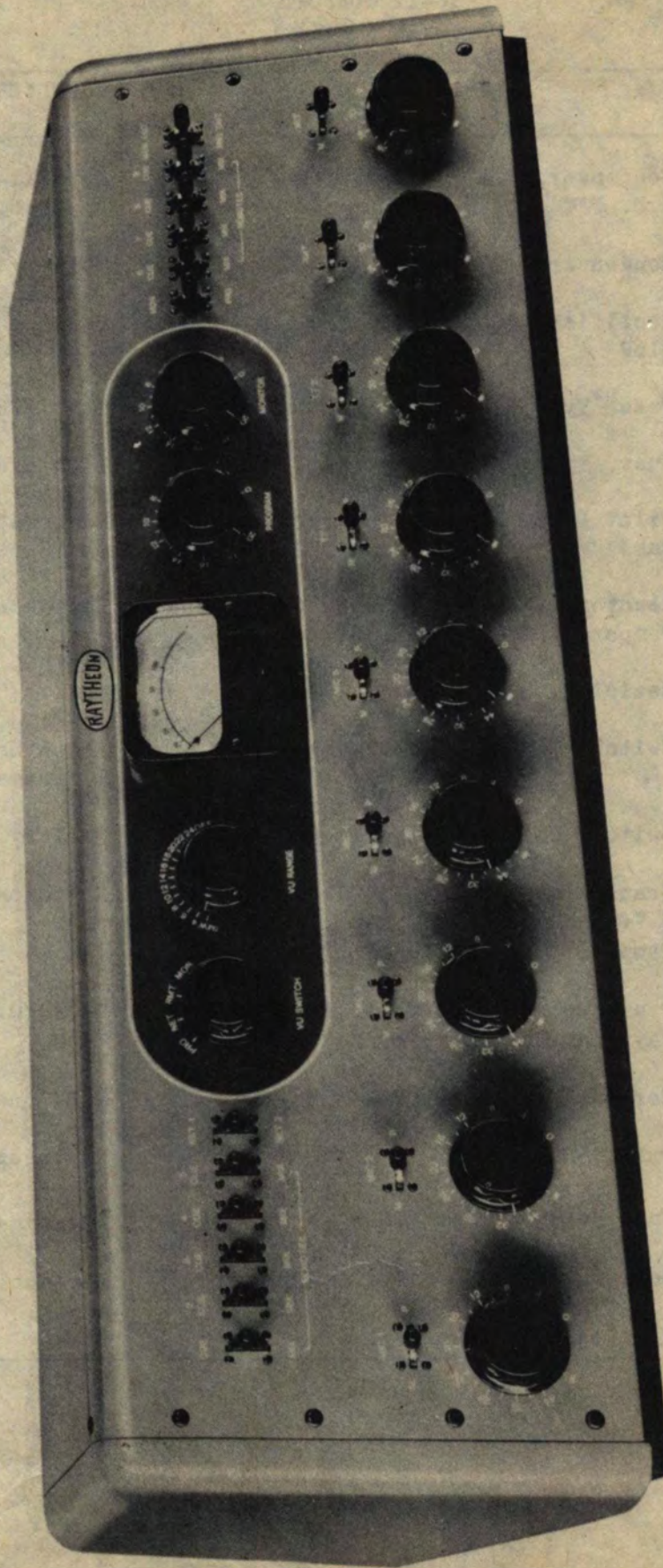
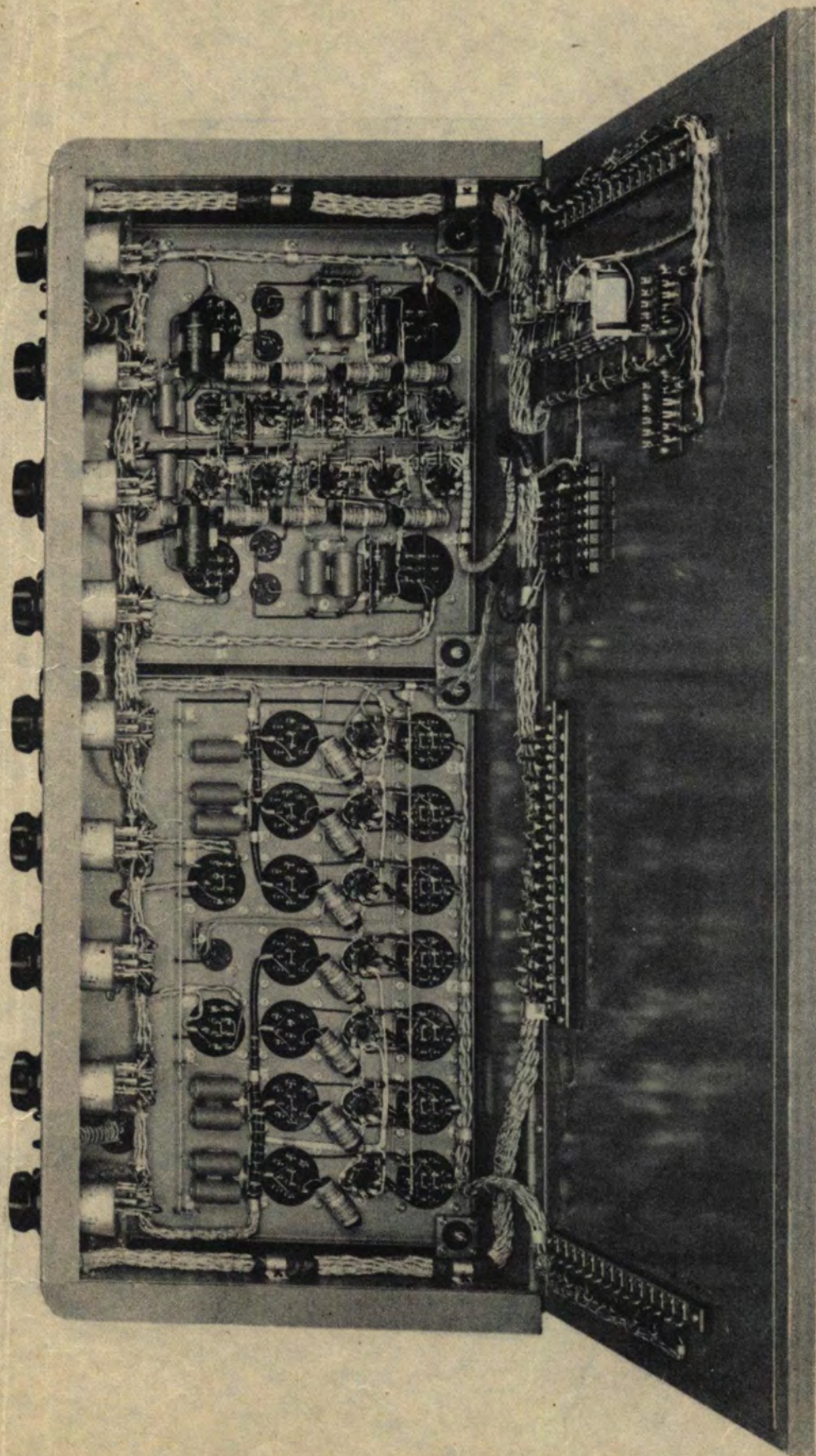

FIG I. RC-II CONSOLE FRONT



PH-37

FIG 2. RC-II CONSOLE WIRING

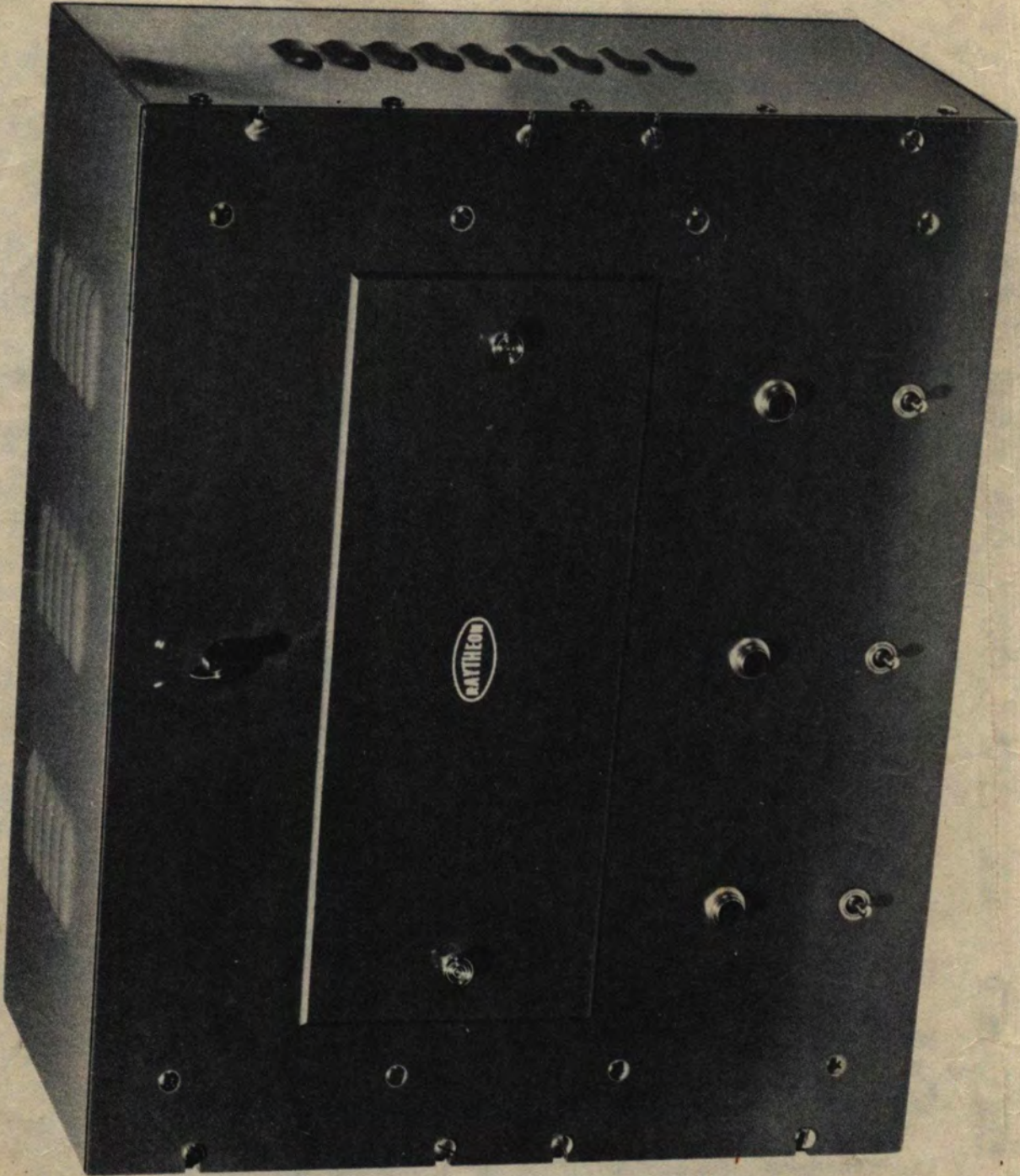
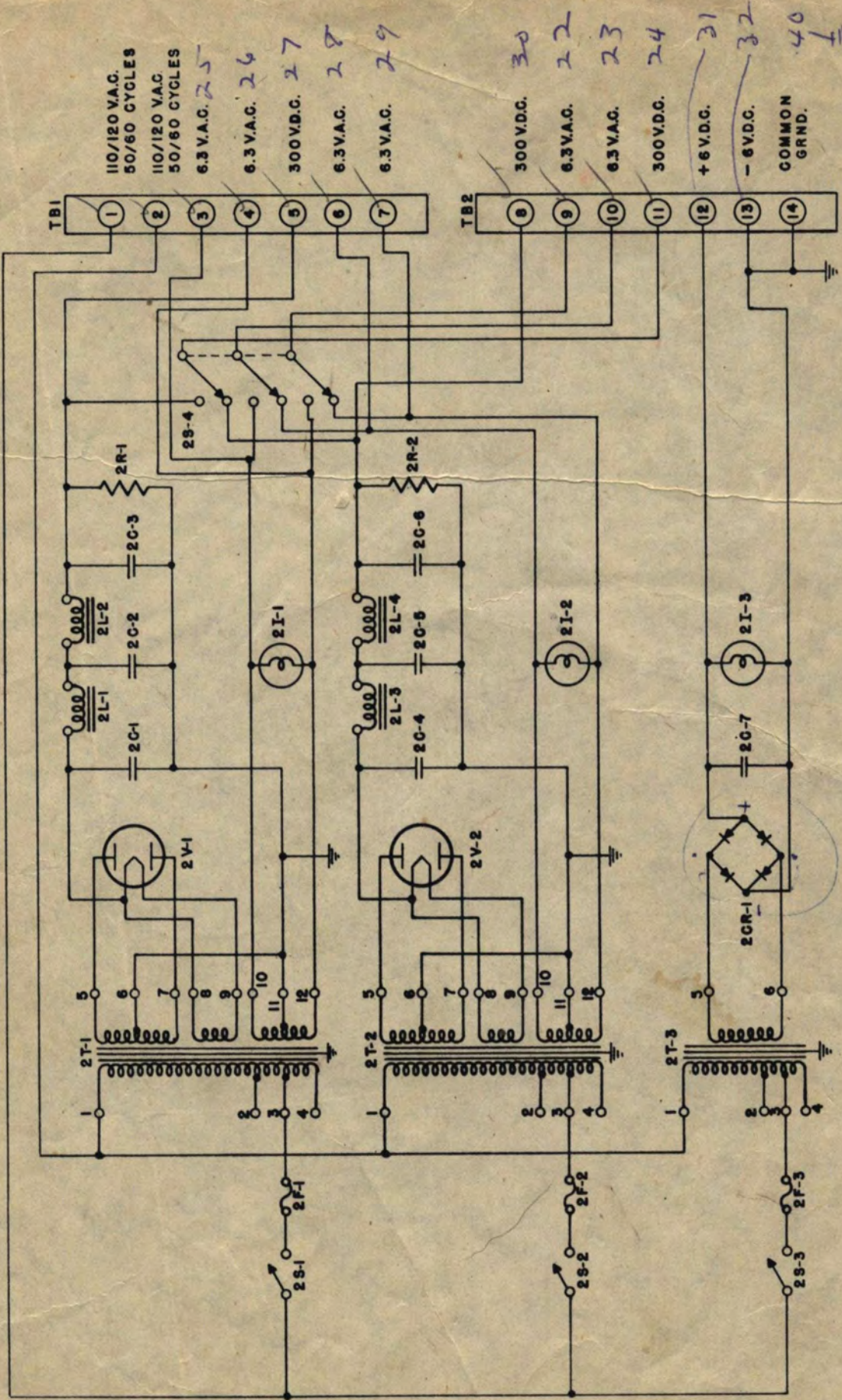

FIG 3. RC-II CONSOLE POWER SUPPLY



110/120 V.A.C. 50/60 CYCLES  
 110/120 V.A.C. 50/60 CYCLES  
 6.3 V.A.C. 25  
 6.3 V.A.C. 26  
 300 V.D.C. 27  
 6.3 V.A.C. 28  
 6.3 V.A.C. 29  
 300 V.D.C. 30  
 6.3 V.A.C. 22  
 6.3 V.A.C. 23  
 300 V.D.C. 24  
 +6 V.D.C. 31  
 -6 V.D.C. 32  
 COMMON GRND. 40

DR. G.S. ... DATE 2-14-46 APP. P.T. GHK:JK  
**RC 10 CONSOLE POWER SUPPLY**  
 FIRST USED ON *RC-11*  
**RAYTHEON MFG. CO.**  
 COMMUNICATION DIV. CHICAGO  
**88-V-4-A**

Fig. 7

Hall Office - 2608  
 Stair - 2550  
 Copy - 2500  
 Control -  
 Black & Brown

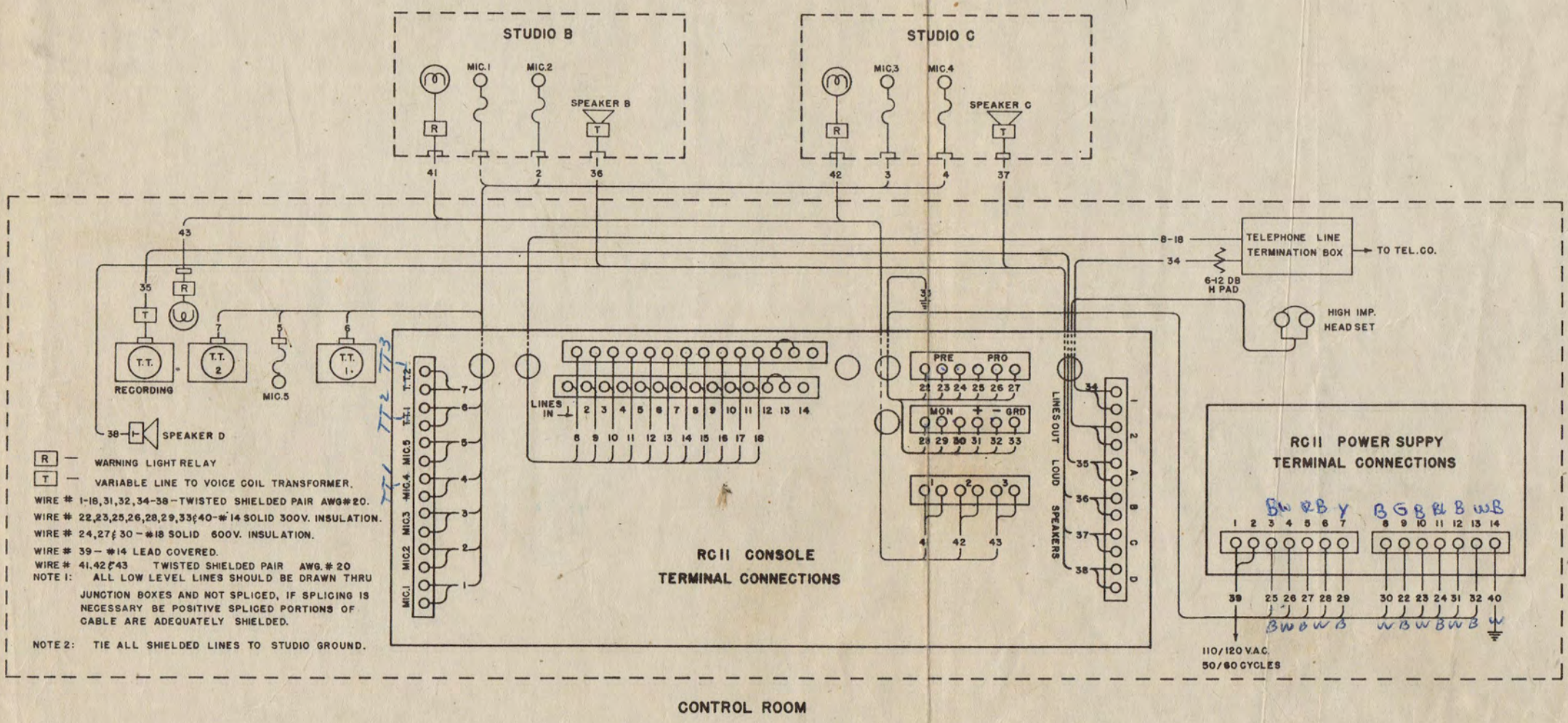
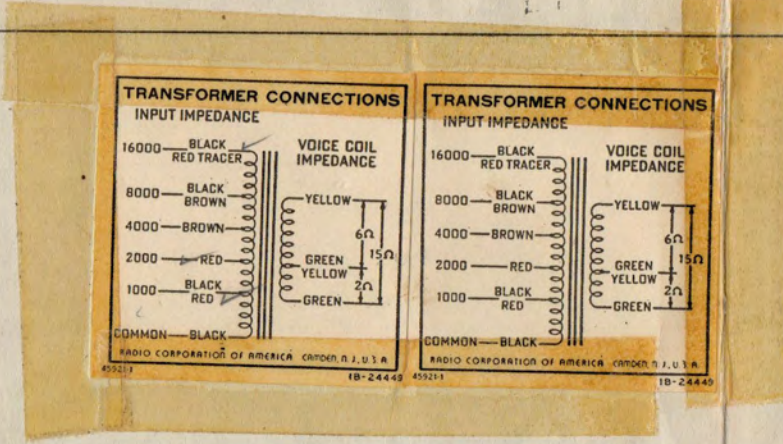

If You Didn't Get This From My Site,  
 Then It Was Stolen From...  
[www.SteamPoweredRadio.Com](http://www.SteamPoweredRadio.Com)

REV. NO.	REVISION	DATE	BY
1	REVISED FOR PROX ORDER #8554 RCII	APR 1946	PT
2	ADDED WARNING LIGHT RELAY TO BOX-UP	APR 1946	PT

DR. W. L. Aron	DATE 3 12 46 APP.	CHK.
FIG. 4. STUDIO WIRING DIAGRAM		
FIRST USED ON RC10 CONSOLE & RCII 7509 8554		
RAYTHEON MFG. CO.	88-W-7C	PAGE 17

1030

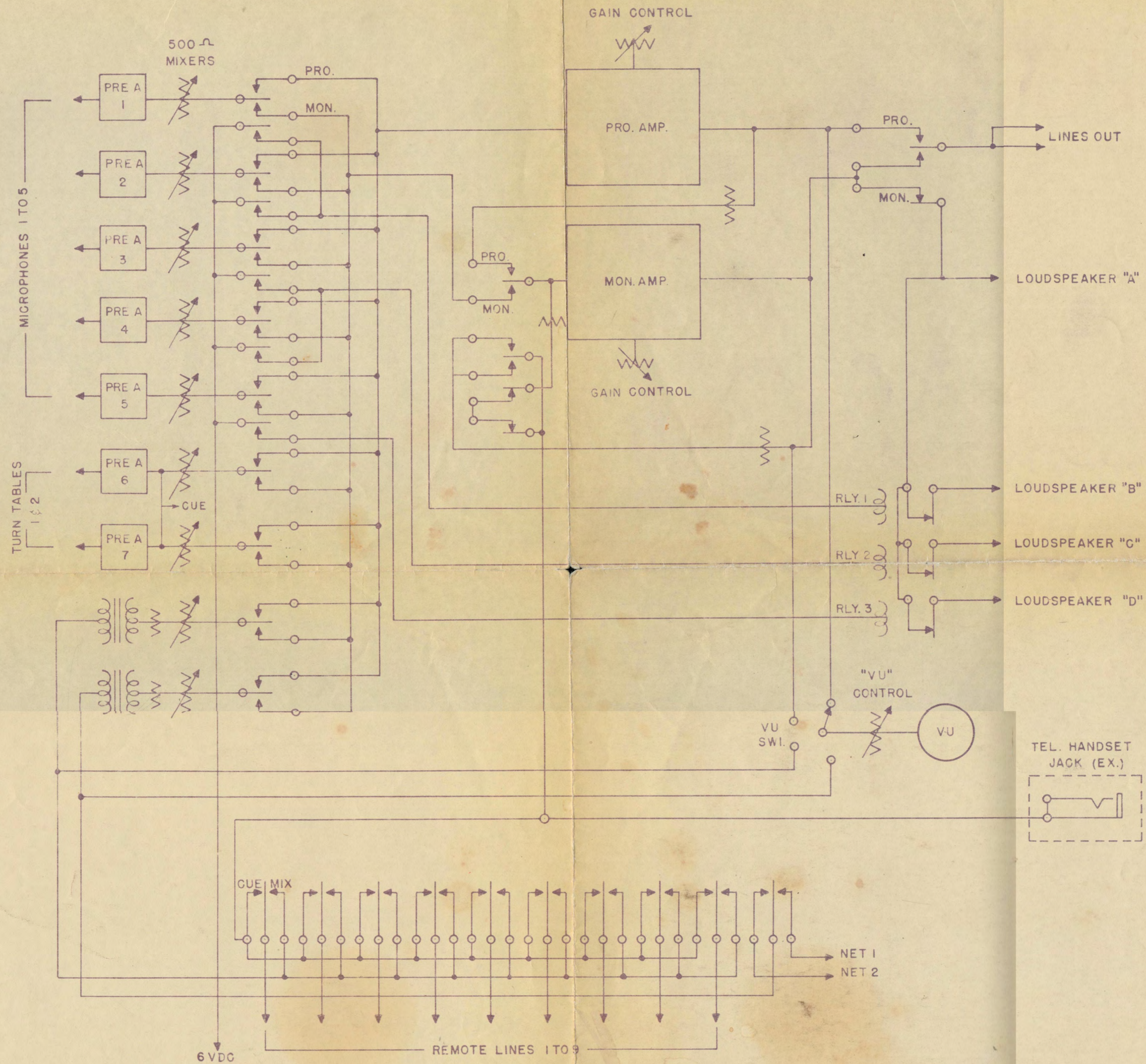

REF 88-V-8

DR. *W.S. Rogers* DATE 3-14-46 APP. PT. CHK. *JJK*

**RCII CONSOLE BLOCK DIAGRAM**

FIRST USED ON

SUB.

**RAYTHEON MFG. CO.**  
COMMUNICATION DIV. CHICAGO

C2-15423



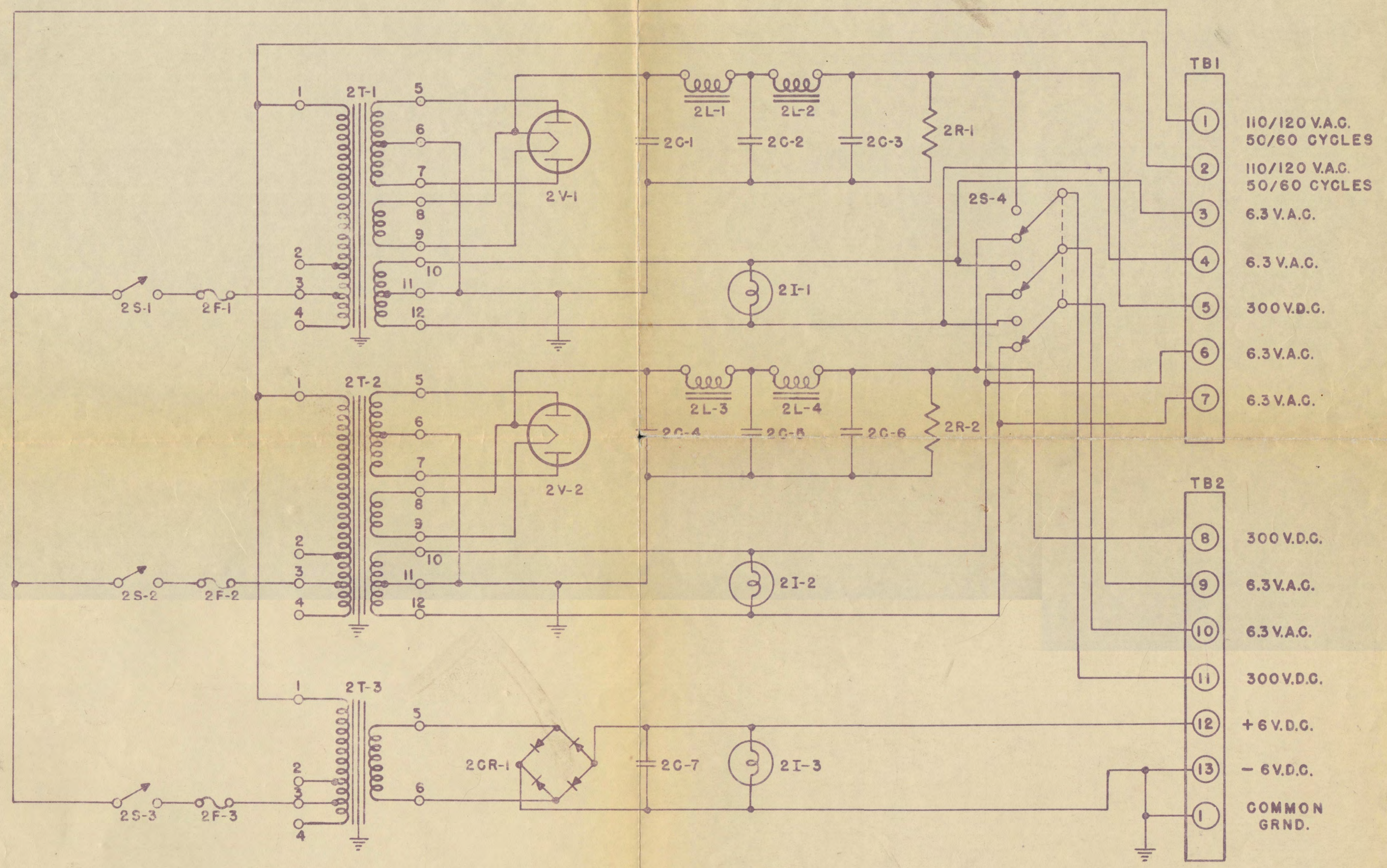

FIG. 7  
FOR REF. 38-V-4A

DR. <i>W.S. Rogers</i> DATE 2-14-46 APP. PT. <i>CHK. SK</i>	
<b>RC 10 CONSOLE POWER SUPPLY</b>	
FIRST USED ON <i>and RC-11.</i>	SUB
<b>RAYTHEON MFG. CO.</b> COMMUNICATION DIV. CHICAGO	<b>C215394</b>

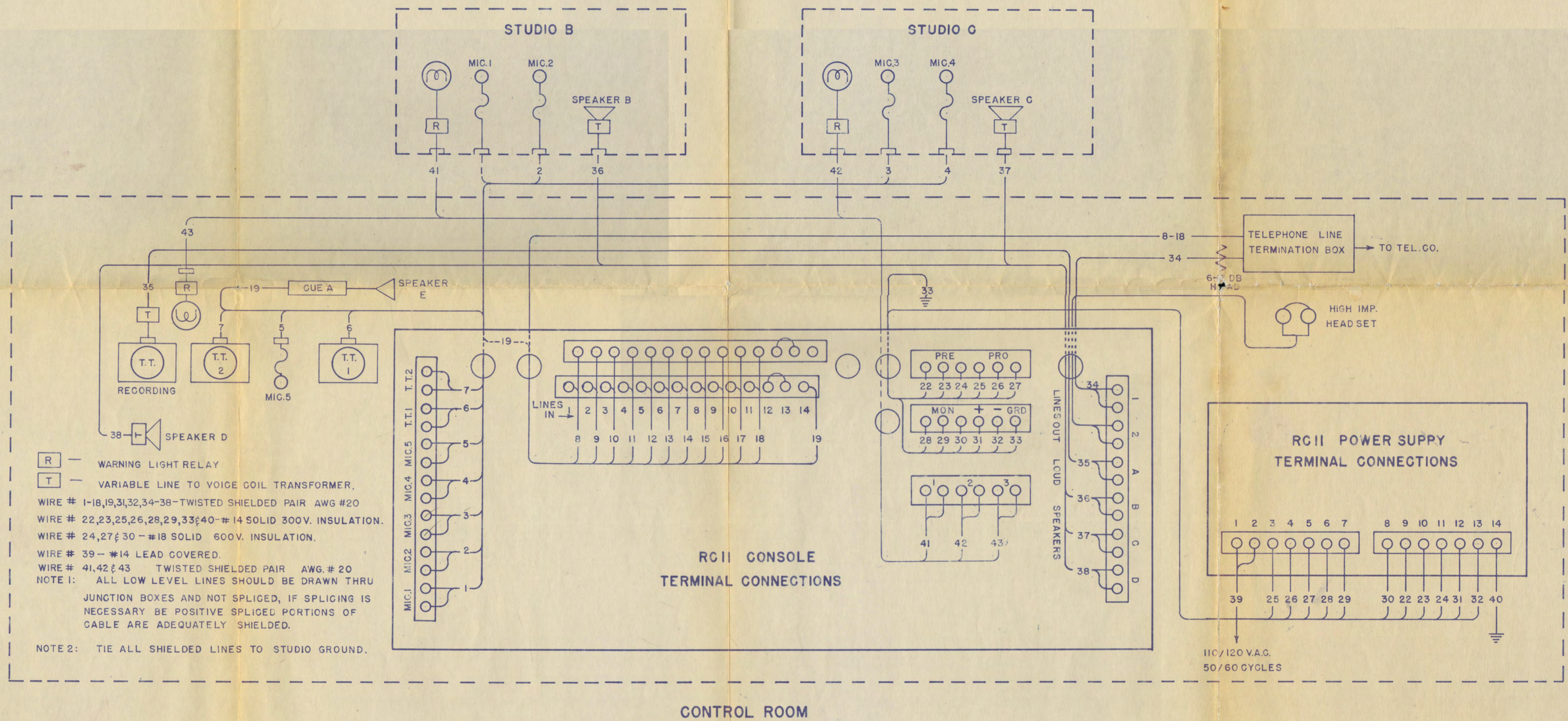
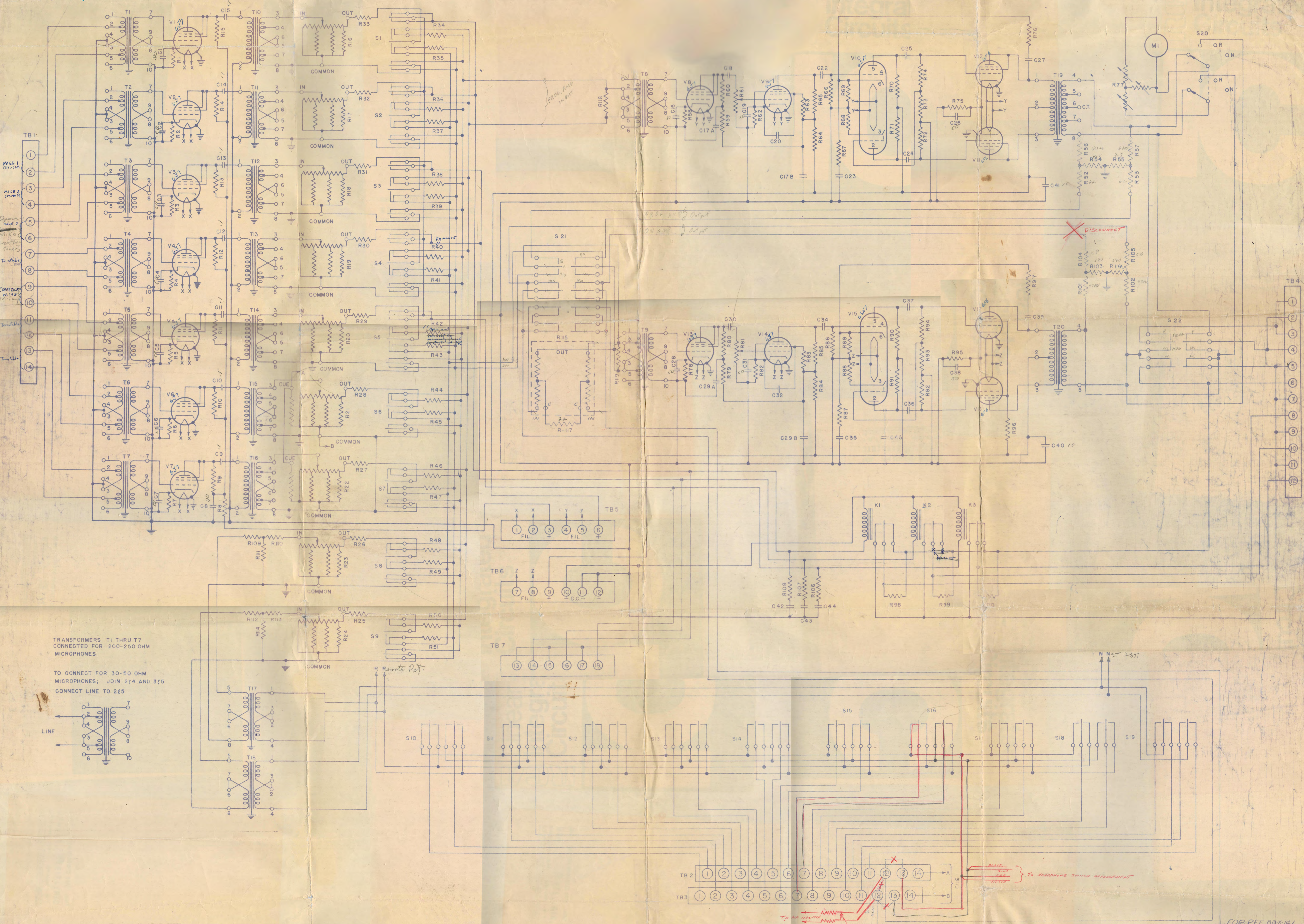

FIG. 4

DR. <i>W.L. Ryan</i>	DATE 3 12 46	APP. <i>CHK.</i>
<b>STUDIO WIRING DIAGRAM</b>		
FIRST USED ON RC10 CONSOLE & RCII 7509-8554		
<b>RAYTHEON MFG. CO.</b>		D2-15483
COMMUNICATION DIV. CHICAGO		

88-12-183



TRANSFORMERS T1 THRU T7  
CONNECTED FOR 200-250 OHM  
MICROPHONES

TO CONNECT FOR 30-50 OHM  
MICROPHONES; JOIN 2&4 AND 3&5  
CONNECT LINE TO 2&5

