

**RADIO AIDS
TO MARINE NAVIGATION**

Finished Jan 23, 1961

54RC-1

NATIONAL RADIO INSTITUTE

ESTABLISHED 1914

WASHINGTON, D. C.

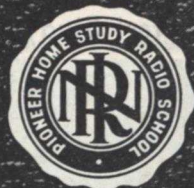

STUDY SCHEDULE NO. 54

For each study step, read the assigned pages first at your usual speed, then reread slowly one or more times. Finish with one quick reading to fix the important facts firmly in your mind. Study each other step in this same way.

1. Principles of Navigation Pages 1-4

The basic principles of celestial navigation are discussed in this section.

2. The Marine Radiocompass Pages 5-15

This section contains a discussion of the theory and practice of determining a ship's position with unilateral and bilateral radio compasses.

3. Typical Radiocompass Installations Pages 15-20

Various typical radiocompasses, including the Radiomarine AR-8709, are described in this section.

4. Loran Pages 21-25

The loran system of marine navigation is discussed in this section.

5. Radar Pages 25-36

Here you learn the basic principles of the radar equipment used in merchant vessels.

6. Answer Lesson Questions.

7. Start Studying the Next Lesson.

RADIO AIDS TO MARINE NAVIGATION

Principles of Navigation

NAVIGATION is coming into the province of the ship's radio operator because of the increasing importance of various radio aids to navigation. It is possible to operate such aids without knowing very much about navigation, but if you intend to become a marine operator, you will be able to do your job better if you understand the basic principles of navigation as well as the workings of the radio equipment used in it.

GEOGRAPHICAL COORDINATES

A ship's position is always given in terms of latitude and longitude. These two names come from a system of geographical coordinates in which the earth's surface is considered to be criss-crossed by "parallels of latitude" (imaginary lines encircling the earth parallel to the equator) and "meridians of longitude" (imaginary lines encircling the earth and passing through both poles).

Both latitude and longitude are measured in degrees. The equator is considered to be the zero parallel of latitude; any other parallel is measured by the angle between a line drawn from the center of the earth to the parallel and a line drawn from the center of the earth to the equator. The method of determining the 20°, 40°, 60°, and 80° parallels north of the equator is shown in Fig. 1. Since every parallel north of the equator has a counterpart south of the equator, latitude is given in degrees "north latitude" or "south latitude."

The zero meridian of longitude is, by

international agreement, the meridian passing through Greenwich, England. Meridians are considered to be the intersection between the surface of the earth and imaginary planes passing through both poles; consequently, any meridian can be measured in terms of the angle between its plane and the plane of the zero meridian. The method of determining the 90° meridian is shown in Fig. 2. Meridians are measured as so many degrees east or west of the zero meridian; the 180-degree meridian is, of course, on the opposite side of the world from the zero meridian.

The distance between successive degrees of longitude along the equator is 60 nautical miles. (A nautical mile is approximately 1.15 statute, or land, miles.) This distance decreases at successively higher parallels of latitude,

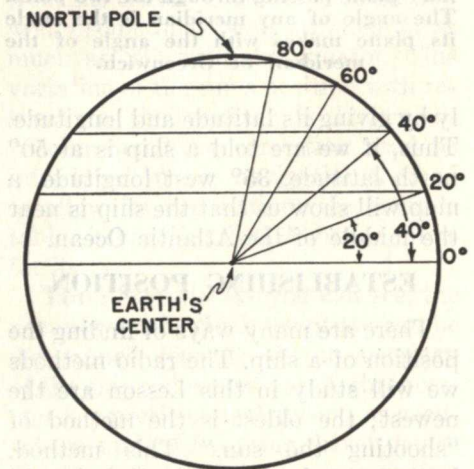

FIG. 1. How the parallels of latitude are determined.

becoming zero at the two poles. The distance between successive degrees of latitude is roughly 60 nautical miles, although this distance varies somewhat, because the earth is not perfectly round.

This coordinate system permits the position of a ship to be specified exact-

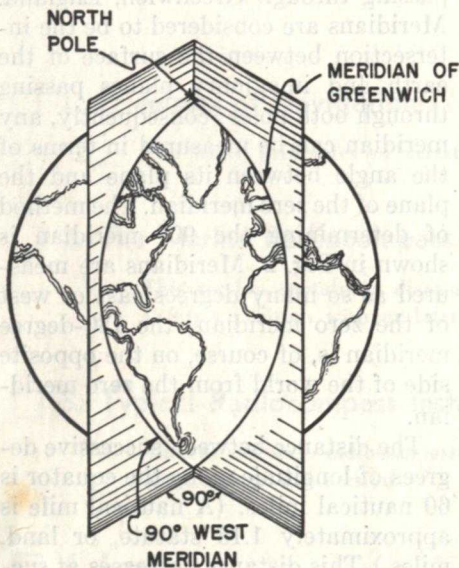

FIG. 2. Each meridian is the intersection between the earth's surface and an imaginary plane passing through the two poles. The angle of any meridian is the angle its plane makes with the angle of the meridian of Greenwich.

ly by giving its latitude and longitude. Thus, if we are told a ship is at 50° north latitude, 35° west longitude, a map will show us that the ship is near the middle of the Atlantic Ocean.

ESTABLISHING POSITION

There are many ways of finding the position of a ship. The radio methods we will study in this Lesson are the newest; the oldest is the method of "shooting the sun." This method, known as celestial navigation, is still the basic method of determining a ship's position.

Celestial navigation is based on the fact that the sun's position in relation to the earth for any time of any day in the year is very accurately known. Let us assume that the sun is always directly in line with the equator, and that the earth rotates at a rate of exactly one revolution every 24 hours. (We shall see in a moment what allowances must be made because these conditions are not exactly true.)

Suppose now that we are on the equator and on the zero meridian. Exactly at noon Greenwich time, the sun will have reached its highest point in the sky—in fact, it will be directly over our heads. At the same time, the sun will be at its highest point to anyone else anywhere on the zero meridian (although it will not be directly overhead except to someone at the equator). Thus, the position of the sun gives us two pieces of information about our position: the fact that the sun is at its highest point in the heavens exactly at noon Greenwich time shows that we are on the zero meridian, and the fact that it is then directly overhead (that is, at an angle of 90° to the horizon) shows that we are on the equator.

If, instead, we are somewhere else on the zero meridian, we can find our latitude by measuring the angle between the sun and the horizon, since this angle will differ for every point between the equator and the North Pole (or for every point between the equator and the South Pole). This measurement can be made very accurately with an instrument known as a sextant. Navigation tables are available (contained in a publication called the Nautical Almanac) that show what each angle means in terms of latitude. Therefore, we can look up the measured angle in the proper table and find out where we are on the zero meridian. Of course, we will have to know whether we are north or south of the

equator, because the angle measured at any point north of the equator can be duplicated by a measurement made at a corresponding point south of the equator, but this is not much of a problem—if the sun is south at the moment of measurement, we know we are north of the equator; if the sun is north, we are south of the equator.

You can see, then, that it is very simple to find our position if we are on the zero meridian. It is not much more difficult to find our position if we are on some other meridian; all we need, in addition to a sextant and navigation tables, is an accurate clock (called a chronometer) that indicates Greenwich time. To find our position, we must, as we did before, make a measurement of the sun's angle with the horizon when the sun is at its highest point in the sky. In addition, we must make a note of the exact time at which the measurement is made. Looking up the angular measurement shows us our latitude. We can find our longitude by using the fact that the earth rotates at a regular rate so that the sun appears to move 15 degrees of longitude per hour (360° in 24 hours). In other words, at 15° west of Greenwich, noontime (the time when the sun is at its highest point) occurs one hour later than it does at Greenwich. Since our chronometer always shows Greenwich time, all we have to do is to see how far the time at which we took the noontime measurement is from 12 o'clock Greenwich time, and convert this time difference into degrees of longitude (remembering that one hour difference equals 15°). Thus, if our noontime measurement was made at 2 o'clock Greenwich time, we must be 30° west of Greenwich. As a matter of fact, no computation is necessary—just looking up the time difference in the navigational tables will show us our longitude.

That is all that is involved in determining a ship's position by celestial navigation. A correction must be made in determining longitude, because the earth does not make exactly one revolution every 24 hours. This means that time kept by a clock does not always coincide with sun time; for example, the sun is not always at its highest point at 12 o'clock. As a matter of fact, there may be a variation of as much as 16 minutes between clock time and sun time. This variation is known for every day of the year.

What we have called "clock time" is generally known as Greenwich Mean Time (GMT); "sun time" at Greenwich is called Greenwich Apparent Time (GAT). The variation between GMT and GAT is called the "equation of time," and is given for each day of the year in the Nautical Almanac. Adding the correction to the chronometer reading (or subtracting it—the tables indicate which to do) gives GAT, which can then be used to determine the longitude.

We assumed that the sun is always in line with the equator. This is not always the case; in fact, a line drawn from the center of the earth to the sun would sometimes be at an angle of as much as 23° with the equator. This variation of the sun's position with respect to the equator is known as "declination." No correction need be introduced in our navigation method to allow for declination; the latitude tables in the Nautical Almanac allow for it.

Time Signals. As you can see, the accuracy with which longitude can be determined depends on the accuracy of the ship's chronometer. A chronometer is a precision instrument, as accurate as a portable, spring-driven device can be, but it is by no means perfect in its ability to keep time. To assist navigators in making accurate time

measurements, time signals are broadcast by various stations at various periods of the day. These signals indicate Greenwich Mean Time with an accuracy of 1/10 second or better. One of the important duties of the radio operator is to pick up these signals once a day, preferably close to noon, so that the amount of chronometer error can be determined. (Incidentally, the chronometer is never reset aboard ship, no matter how much in error it becomes; a daily record of the error is kept, and the time readings are corrected accordingly. This procedure avoids the possibility of damaging the chronometer.)

Astral Navigation. It is not necessary to use the sun to determine the position of a ship. The stars also have regular, known courses through the heavens, and can be used instead of the sun in making observations. The Nautical Almanac contains tables showing the stars to be used for this purpose.

Celestial navigation methods have

one serious fault: they cannot be used if it is impossible to see the sun or stars. Fog or storms often make the sky invisible for days at a time. Before the advent of the radiocompass, a ship's navigator had to rely on dead reckoning to determine the ship's position under these conditions—that is, he had to estimate where the ship was on the basis of the distance covered and the course followed since the last time he was able to secure a fix. A skillful, experienced navigator can often make surprisingly good estimates of position by dead-reckoning methods, but there are so many variable factors involved—such as ocean currents and human error in steering on a course—that even the best navigator cannot be sure of the accuracy of the results of his dead reckoning.

The marine radiocompass, which we will now study, makes it possible for a navigator to determine his ship's position regardless of weather and visibility conditions, provided he can pick up the proper stations.

The Marine Radiocompass

The principal function of a radiocompass, also known as the radio direction finder, is to provide a check on the older established methods of navigation, particularly during adverse visibility conditions caused by fog, rain, sleet or snow. An indication of its value is the fact that the insurance rate for vessels not having radio direction finders is twice that for vessels equipped with this aid.

The radiocompass should not be considered as having replaced the older methods of navigation. Its accuracy of bearing (about one degree), although sufficient for furnishing useful information, still does not compare with that obtainable by astronomical methods. Its value lies chiefly in its ability to function under bad weather conditions.

The principle of the direction finder is quite simple. Radio waves from a transmitter will go in straight lines in all directions if not distorted by the terrain. Over large bodies of water, there is practically no distortion; by determining the direction of arrival of the radio waves, you can determine the direction of the transmitter with respect to the ship (i.e., its "bearing"). If you plot on a map a line that goes through the known position of the transmitter at the indicated bearing, your ship is somewhere on that line. Taking a bearing on another transmitter and plotting it on the same map gives you a second line; the point where the two lines intersect is the ship's approximate position.

The U. S. Lighthouse Service has established a network of fixed radio beacon stations along the coasts and near the Great Lakes. Fig. 3 shows the network along a portion of the East Coast. The stations have known geo-

graphical positions and their transmissions are keyed with characteristic signals to make it possible to identify them.

All American ships carry the current edition of "Radio Aids to Navigation" published yearly by the Navy Hydrographic Office. All beacons and radiocompass stations throughout the world are listed, together with geographic coordinates, sequence of operation, power, frequency, and other characteristics of emission. This book is kept in the chart room, near the radiocompass.

Radiocompass operators on ships use a directional loop antenna to take bearings on these fixed stations for determining the ship's position and heading. A typical installation on a small vessel is shown in Fig. 4.

An alternate system of radio direction finding utilizes fixed direction finders on shore with the transmitting station on shipboard. A ship requiring a "fix" transmits a message to the shore stations asking for this information. Two or more shore stations take bearings on the ship transmitter and, by triangulation, determine the ship's position. This information is then transmitted to the ship. Since the radio direction finder is located on shore, large antenna structures may be used. The advantage of these antenna systems over the small rotating-loop antenna lies in the greater accuracy attainable, of the order of 0.5 degree.

Foreign radiocompass stations make a charge for bearing service, so if the captain should ask you to obtain a shore bearing, do not forget to show the charges on your message abstract and radio operating log. There is no charge, of course, for bearings you take with the ship's radiocompass.

Just record them in your radio operating log (to show why you left the operating position) when you are asked to take them.

DIRECTIONAL PROPERTIES OF LOOP ANTENNAS

The loop antenna consists of one or more turns of wire in any con-

venient form. In the larger antennas used on shore, single-turn loops are employed; the shape may be triangular (see Fig. 5A) to permit support by a single pole, or hexagonal (see Fig. 5B) to afford maximum area for a given height. The loop is tuned to resonance with the frequency of the transmitting station by the tuning condensers.

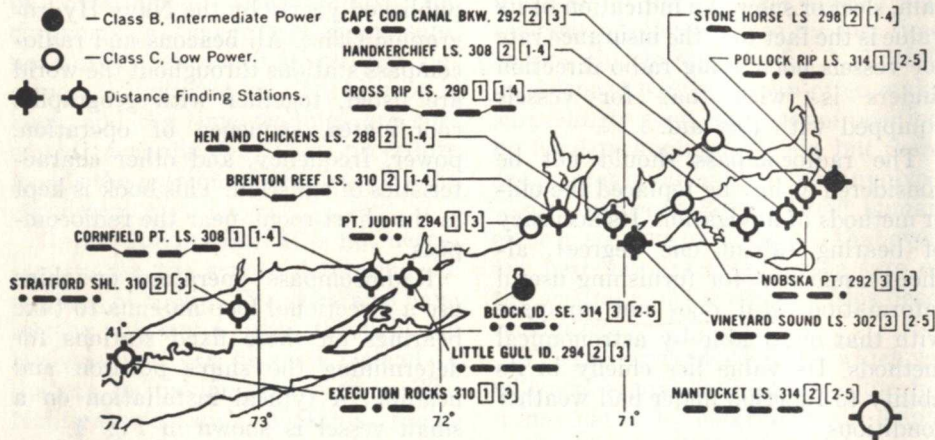

FIG. 3. Nantucket, Vineyard, and Long Island Sound portion of a map prepared by United States Lighthouse Service to show the Radio-beacon System of the Atlantic and Gulf Coast. Abbreviations are: PT—Point; LS—Lightship; ID—Island; SHL—Shoal; BKW—Breakwater. The frequency of each station in kc. is given after the name. The characteristic dot-and-dash signal radiated is given below the station name. The dashes at different levels, joined together by thin lines, indicate that high and low tones of modulation are used.

The number in the square following the frequency of a station indicates the schedule assigned to that station. Up to three radio-beacon stations may be assigned the same frequency; to prevent interference in such a case, three schedules are used, as indicated below, so that each station can operate for only one minute at a time; this operation must be during one of the one-minute periods indicated in its assigned hourly (60 minute) schedule.

Schedule 1: 0 to 1, 3 to 4, 6 to 7, 9 to 10, 12 to 13, 15 to 16, 18 to 19, 21 to 22, 24 to 25, 27 to 28, 30 to 31, 33 to 34, 36 to 37, 39 to 40, 42 to 43, 45 to 46, 48 to 49, 51 to 52, 54 to 55, 57 to 58.

Schedule 2: 1 to 2, 4 to 5, 7 to 8, 10 to 11, 13 to 14, 16 to 17, 19 to 20, 22 to 23, 25 to 26, 28 to 29, 31 to 32, 34 to 35, 37 to 38, 40 to 41, 43 to 44, 46 to 47, 49 to 50, 52 to 53, 55 to 56, 58 to 59.

Schedule 3: 2 to 3, 5 to 6, 8 to 9, 11 to 12, 14 to 15, 17 to 18, 20 to 21, 23 to 24, 26 to 27, 29 to 30, 32 to 33, 35 to 36, 38 to 39, 41 to 42, 44 to 45, 47 to 48, 50 to 51, 53 to 54, 56 to 57, 59 to 60.

Numbers in brackets, following the schedule number, indicate the ten-minute periods of each hour during which the station operates in its assigned schedule. The six periods in each hour are designated as follows: 1—0 to 10 min.; 2—10 to 20 min.; 3—20 to 30 min.; 4—30 to 40 min.; 5—40 to 50 min.; 6—50 to 60 min.

Here are two examples: Nantucket Lightship operates on 314 kc., following schedule 2 during the second and fifth periods of each hour (10 to 11, 13 to 14, 16 to 17, 19 to 20, 40 to 41, 43 to 44, 46 to 47, 49 to 50), and using a four-dash signal of constant tone. Cornfield Point Lightship operates on 308 kc., following schedule 1 during the first and fourth periods of each hour (0 to 1, 3 to 4, 6 to 7, 9 to 10, 30 to 31, 33 to 34, 36 to 37, 39 to 40), and using a four-dash signal with the second and third dashes lower in tone than the others.

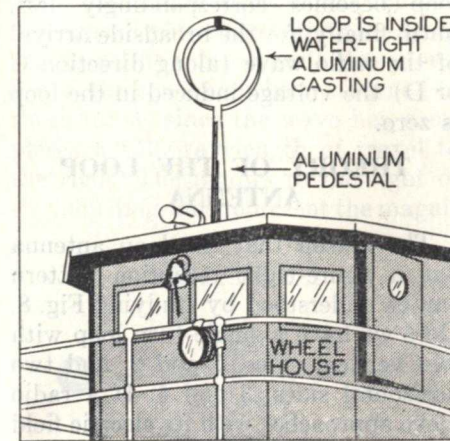

FIG. 4. Typical radiocompass loop installation on top of the wheel house of a vessel. The loop is mounted in a water-tight aluminum casing and is supported by a hollow aluminum pedestal through which the loop leads run. The remainder of this radiocompass installation is mounted in the wheel house, directly under the loop.

The voltage induced in the loop antenna is proportional to the area of the loop. As a result, the small loop antenna used in the modern ship radiocompass has a low voltage induced in it and hence requires a sensitive receiver. Such loops may be round or rectangular in shape, and usually are about three feet square. To increase its effective induced voltage, it has from sixteen to twenty turns of wire, wound in solenoid form (see Fig. 6) so that the voltages induced in the several turns add.

An advantage of the small loop is that it may be enclosed in a tubular metal shielding, thus providing weather protection for the windings. The shield is broken at one point (usually the top) so that the voltage induced in it is not short-circuited. This voltage is in turn transferred to the loop winding by transformer action. The loop shown in Fig. 4 is shielded.

To determine the directional char-

acteristics of a loop antenna, a portable transmitter is carried in a circle around a fixed loop antenna, at a constant distance from the center of the loop. For every 10° or so, the voltage induced in the loop is measured. Radial lines are drawn from the center of the loop toward each point at which a measurement was made, such as the lines A, E, K, C, G, B, H, D, and F in Fig. 7. (Notice that the loop is perpendicular to the earth's surface.) To plot the response, a distance is measured (out from O along each line) that is proportional to the magnitude of the induced voltage obtained when the transmitter is on that line, and these points are marked with large dots. The figure-eight curve joining these dots is a "polar" diagram; it illustrates how the response of the loop antenna varies as a function of the angle of arrival of the received radio wave.

In referring to the position or direction of a loop antenna, we will use the term "plane of the loop." The plane of a loop is an imaginary plane, infinite

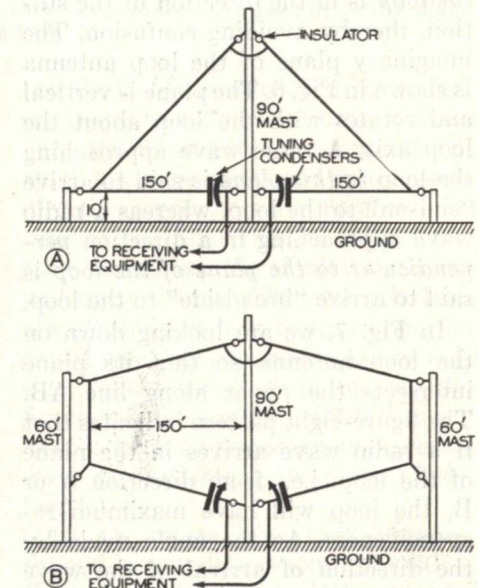

FIG. 5. Two kinds of antennas used in radiocompass installations on shore.

in extent, that passes through the center of the loop and is parallel to the loop wires. It could hardly be stated that a loop is "pointing" to a certain transmitting station, because a loop is square or circular and cannot point; for this reason we say that the plane of

loop becomes correspondingly less, until, finally, for the broadside arrival of the radio wave (along direction C or D) the voltage induced in the loop is zero.

THEORY OF THE LOOP ANTENNA

The reason that the loop antenna has a figure-eight reception pattern can be understood by studying Fig. 8. Here we have a single-turn loop with two vertical sides, 1 and 2, and two horizontal sides, 3 and 4. If a radio wave approaches with its electric field vertically polarized (the usual case), the field will line up with the vertical sides of the loop, and can induce no voltage in the horizontal elements; these serve simply as connectors for adding together in proper phase the voltages induced in the two vertical members. Suppose first that the loop

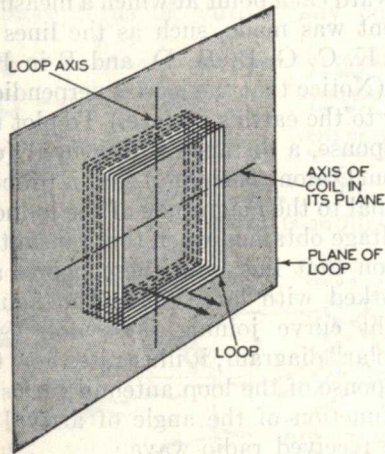

FIG. 6. The typical loop antenna used aboard ship has multiple turns to increase pickup.

the loop is in the direction of the station, thereby avoiding confusion. The imaginary plane of the loop antenna is shown in Fig. 6. The plane is vertical and rotates with the loop about the loop axis. A radio wave approaching the loop in this plane is said to arrive "end-on" to the loop, whereas a radio wave approaching in a direction perpendicular to the plane of the loop is said to arrive "broadside" to the loop.

In Fig. 7, we are looking down on the loop antenna so that its plane intersects the paper along line AB. The figure-eight pattern indicates that if a radio wave arrives in the plane of the loop, i.e., from direction A or B, the loop will have maximum responsiveness. As the angle made by the direction of arrival of the wave with the plane of the loop antenna increases, the voltage induced in the

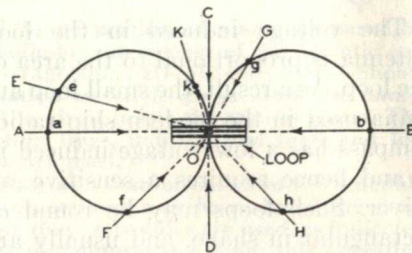

FIG. 7. The reception pattern of a loop antenna. Notice that it has zero pickup for a wave coming from either C or D.

is oriented so that the wave arrives in the plane of the loop, as in Fig. 8. The conditions shown here correspond to successive intervals of time between which the wave travels through a quarter wavelength. At A, the voltages induced in vertical sides 1 and 2 are equal and both produce currents acting in the same direction, so that they cancel. At B, the induced voltages are again equal, but much smaller than at A and their currents flow in opposite directions so they add. At C the cur-

rents are again large, equal, and in the same direction. At D they are again small and flow in opposite directions. For E the conditions have returned to those for A, since the wave has completed a full wavelength of travel to the right. The arrows to the right of the loop diagrams represent the magni-

is turned so that the wave arrives at an angle to its plane. The distance between the two vertical sides of the loop along the direction of travel of the radio wave is effectively reduced, so that the magnitude of the resultant induced current is also reduced. Finally, suppose that the loop antenna is

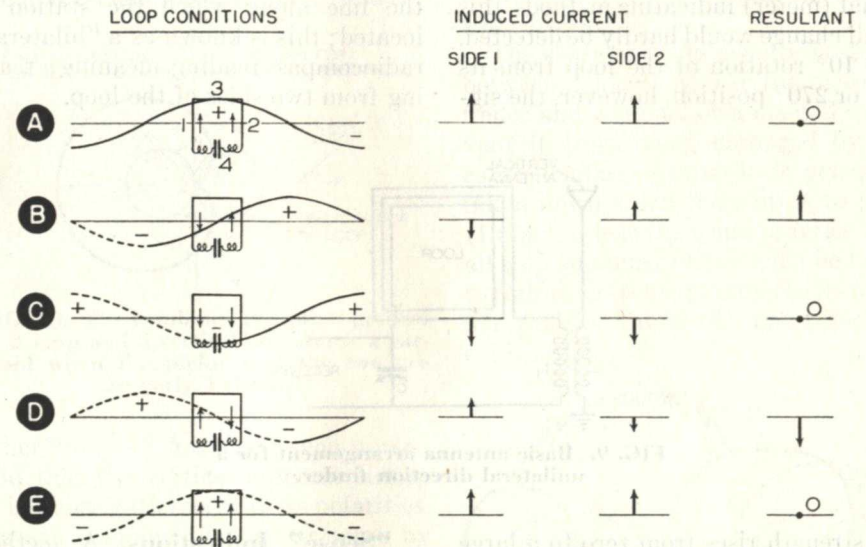

FIG. 8. How the current induced in a loop varies as a radio wave goes by in the plane of the loop.

tudes and directions of the induced currents for the five conditions.

It must be noted that horizontal sides 3 and 4 of the loop operate to connect the currents induced in sides 1 and 2. The resultant current for conditions A, C, and E are therefore zero, and for B and D are a maximum, as shown in the right-hand column.

The maximum instantaneous value of the resultant induced current depends upon the separation of the two vertical conductors along the direction of travel of the wave; this is evident in Figs. 8B and 8D, which show that the greater the space, the greater the wave amplitude enclosed by the loop, and hence the greater the current.

Suppose now that the loop antenna

broadside to the direction of arrival of the radio wave. The instantaneous currents induced in sides 1 and 2 will at all times be equal and in the same direction since the wave reaches both sides at the same time, so that, when they are added, the resultant current will always be zero. Therefore, the loop always receives best from a direction in its plane, and poorest from its broadside. When the loop is turned, the figure-eight reception pattern turns with it, so that its maximums are always directed along the plane of the loop.

If we rotate the loop antenna through a complete revolution (360°), the voltage induced in it by a radio wave will pass through two maximum

values and two zero values, with the greatest change in value occurring as the loop is rotated through a broadside position with respect to the incoming wave. For a 10° variation of the loop antenna from its 0° or 180° position, the signal strength drops from maximum to about 96% of maximum. With either aural (headphone) or visual (meter) indicating methods, this small change would hardly be detected. For 10° rotation of the loop from its 90° or 270° position, however, the sig-

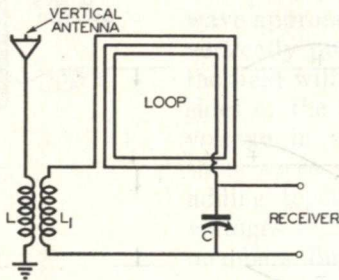

FIG. 9. Basic antenna arrangement for a unilateral direction finder.

approximate position of the ship with respect to the transmitter is known, but there are times when the operator does not know which zero-signal position (90° or 270°) to use. For example, it is impossible to determine in which direction another ship is located by means of the radiocompass alone. The loop antenna alone can only determine the line along which the station is located; this is known as a "bilateral" radiocompass reading, meaning a reading from two sides of the loop.

nal strength rises from zero to a large value (about 17% of maximum). By amplifying the induced voltage obtained when the loop is a small amount off from the zero position, it is possible to adjust for minimum signal and detect even a 1° change in the loop position when it is broadside to the transmitting station. For this reason, the loop antenna is generally rotated for *minimum signal* in radiocompass work.

BILATERAL AND UNILATERAL DIRECTION FINDING

Since there are two maximums and two minimums, there is no way to tell from which of two directions the signal is approaching. A loop may be turned to the zero signal point, but the station transmitting the signal may be located on either side of the loop. Usually the

"Sense" Indications. A method has been developed by which the exact direction of an approaching wave may be found. This is called the "unilateral" method for securing a "sense" indication, and is based on the fact that combining the directional characteristics of a loop antenna with the non-directional characteristics of a vertical antenna will give a cardioid or heart-shaped receiving response pattern. The combination may be like that in Fig. 9, where the small coil L, connected in series with the vertical antenna, is coupled to a second small coil L1, connected in the loop antenna circuit. In this way the voltage induced in the vertical antenna is added to the voltage induced in the loop. By varying the coupling between L and L1, the magnitude of the voltage introduced into the loop circuit from the vertical antenna is adjusted to be

just equal to the maximum voltage induced in the loop by the radio wave when the wave is arriving end-on to the loop.

Fig. 10 shows how the two patterns combine. At any moment of maximum current in the loop, the two induced voltages are in opposite phase. We can indicate this by marking one lobe of the figure-eight pattern "plus," and the

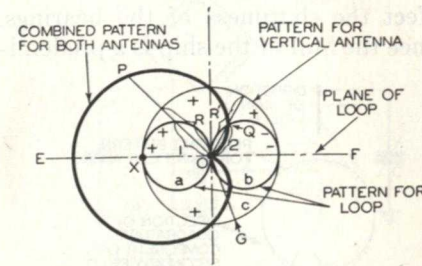

FIG. 10. The combined reception pattern of a loop and a vertical antenna is a cardioid when the pickups of the two are properly balanced.

other "minus." Assuming such a case, and that the vertical antenna pickup is in phase with one of these polarities, we can combine the two patterns by adding with due regard to the signs. Thus, for the direction PO we add the chord 1 to the radius R to get the resultant OP, while for the direction QO we subtract chord 2 from radius R' to get the resultant OQ. The resultant receiving response pattern of the combined antenna system takes the form of a heart-shaped or cardioid pattern. It indicates that when a radio wave arrives at the compass receiving station from the direction F, it cannot be received, whereas from direction E it will be received with maximum intensity. For intermediate directions, such as G, the combined voltage has a value between these two extremes. The antenna system is therefore unilateral and it is now possible to determine the true direction of the transmitting station from the radiocompass.

Because of the much sharper minimums obtained with the bidirectional (figure-eight) arrangement, bearings are generally taken without the use of the sense antenna. Then, the sense (vertical) antenna is connected into the circuit to give the unidirectional (cardioid) arrangement, so as to permit determination of the sense of the bearing, i.e., the true direction of the transmitter.

The sense antenna usually is strung between a location near the direction finder and a funnel or a mast. To prevent it from being damaged by the cargo loading booms, it is generally taken down when the ship is in port. (In fact, this is the usual practice with all ship antennas.) Care must be taken to restore the sense antenna to its original position to avoid upsetting the calibration.

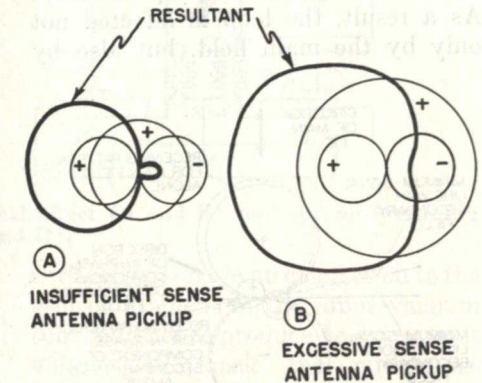

FIG. 11. If the pickups of the loop and sense antennas are not properly balanced, their combined reception pattern will be distorted from the cardioid form.

Fig. 11 shows the effects of variations in the pickup of the sense antenna that makes its signals stronger or weaker than those of the loop antenna. If the sense antenna pickup is insufficient, the resultant retains some of the figure-eight characteristics, producing the "super-cardioid" pattern shown at A. If the sense antenna pick-

up is excessive, on the other hand, the resultant has the almost circular shape shown at B.

CORRECTION FOR VERTICAL AND OTHER SPURIOUS EFFECTS

Obviously, it is important to keep the figure-eight pattern of the loop antenna undistorted and with sharp minimums in order to provide true bearings. Such distortion may be produced by one or more of several effects, which must be considered in the design of the radiocompass.

These effects arise from the installation of the loop near metal objects such as the main body of the ship, rigging, lengths of rail, ventilators, deck houses, funnels, masts, etc. This metal work is energized by the radio field from the shore transmitter, and re-radiates a signal that is picked up by the loop. As a result, the loop is affected not only by the main field, but also by

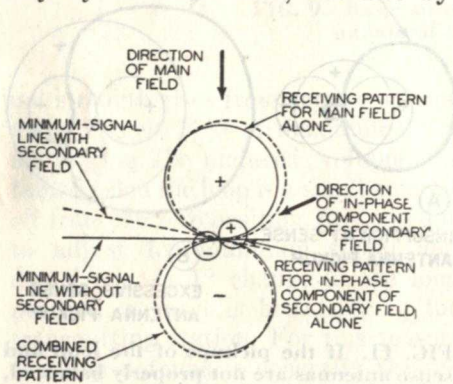

FIG. 12. The distortion of a loop pattern produced in the in-phase component of a reradiated field.

stray fields arriving from wrong directions and with differing phase relations. The stray fields have two components: (1), a field in phase with the main field, but arriving from a somewhat different direction; (2), a field 90° out of phase with the main field. The broken-line pattern in Fig. 12 rep-

resents the pattern when the main field is combined with component (1) of the stray field. The broken-line pattern in Fig. 13 shows the resultant pattern when the main field is combined with component (2) of the stray field.

Quadrantal Error. You can see from Fig. 12 that component (1) produces erroneous bearings but does not affect the sharpness of the bearings. Since the hull of the ship is a predomi-

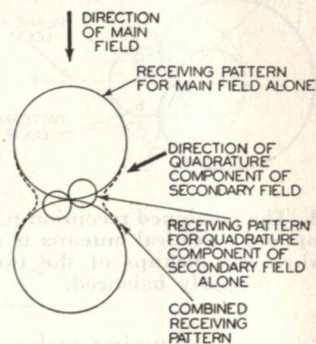

FIG. 13. The distortion of a loop pattern produced by the out-of-phase component of a reradiated field.

nant factor in the production of the secondary field (by reradiation), the bearings will be warped toward the fore-and-aft line of the ship. The errors in the bearings are fixed as long as the ship design is unchanged. A calibration correction curve is prepared the first time the direction finder is put into use. Having this calibration, the navigator may apply suitable corrections to the radiocompass indications and ascertain the true bearings.

From Fig. 13, you can see that component 2 (the quadrature effect) distorts the minimums of the figure-eight, thereby interfering with the taking of accurate bearings. The correction for this will be given later.

Vertical or Antenna Effect. This effect arises from the tendency of the loop as a whole to act as a vertical

antenna because of the capacitance of the set. Referring to Fig. 14A, you can see that one side of the loop is connected to the grid of a tube that has very low capacitance to ground, whereas the other side is connected to the filament and therefore has a much larger capacitance to ground. The impedances between the two loop termi-

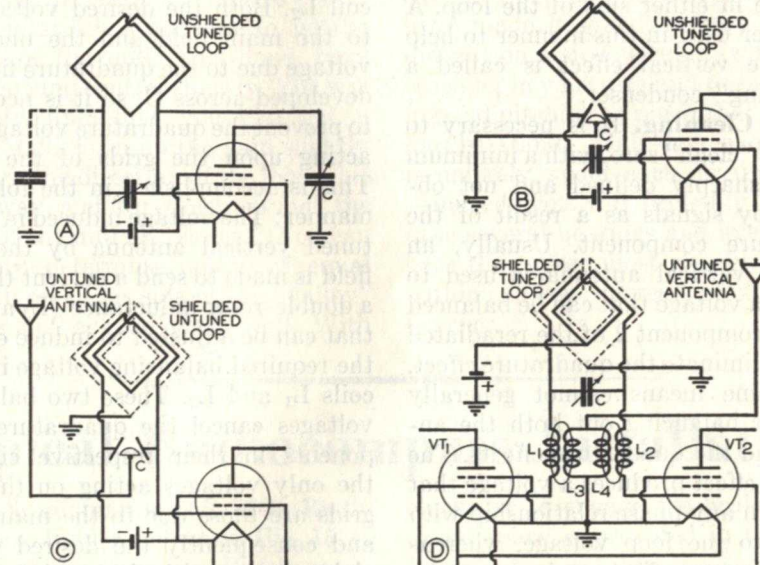

FIG. 14. Circuits used to eliminate vertical effect (A and B) and for zero cleaning (C and D).

nals and ground are therefore quite different, and the voltages in the loop sides force different currents through these impedances, resulting in a voltage difference that appears between the grid and the filament of the tube. The loop minimums are thus masked by the voltage due to the antenna effect. Depending upon the phase of this voltage with respect to the phase of the loop voltage, the resultant pattern may have blurred minimums or may have sharp minimums displaced from their normal positions.

Many methods have been devised for eliminating the vertical effect, only a few of which can be described here. One is to use a tubular shield around

the loop winding, as described earlier in this Lesson. You remember that a break in the shield (at the top) provides for transformer action, so that the net voltage induced in the shield acting as a single-turn loop is transferred to the loop winding. The shield is directly connected to ground at the bottom, and the voltages in its two

vertical sides have no connection to the grid or filament of the input vacuum tube, and hence produce no extraneous voltage to mask the minimums. A second method uses a transformer between the loop and the vacuum tube. A capacity shield between the two windings of the transformer serves to isolate the loop. A third method uses a push-pull input circuit so arranged that the two sides of the loop are connected to the grids of the push-pull input tubes of the receiver and a center tap of the loop antenna is connected to ground. The two loop terminals therefore have equal capacities to ground.

In Fig. 14A, a small condenser C

between the grid and ground makes the capacitance from grid to ground equal to that from filament to ground; there is then no voltage between these two points (other than the true loop voltage), and hence no vertical effect. Fig. 14B shows a later method using a split variable condenser that permits compensations to be made in either side of the loop. A condenser used in this manner to help eliminate vertical effect is called a "balancing" condenser.

Zero Cleaning. It is necessary to obtain a "clean" zero, with a minimum that is sharply defined and not obscured by signals as a result of the quadrature component. Usually, an untuned vertical antenna is used to provide a voltage that can be balanced against component 2 of the reradiated field to eliminate the quadrature effect. (The same means cannot generally serve for balancing out both the antenna and the quadrature effects. The antenna effect produces a voltage that may be in any phase relationship with respect to the loop voltage, whereas the quadrature effect produces a voltage that is 90° out of phase with the normal loop voltage.)

One circuit arrangement used for zero cleaning purposes is shown in Fig. 14C; this uses a split-stator condenser for balancing the vertical antenna voltage against the voltage produced in the *untuned* loop by the quadrature component of the secondary field. When this condenser is properly adjusted, the desired figure-eight pattern with sharp minimums is secured.

Another zero balancing arrangement using a push-pull input circuit is shown in Fig. 14D; balance is secured without upsetting the loop tuning, and hence this circuit can be used with a tuned loop, giving better sensitivity than the circuit in Fig. 14C,

which uses an untuned loop. The loop (Fig. 14D) is tuned by condenser C. Since the midpoint of the loop is grounded, one half of the voltage developed across C is applied to the grid of VT₁ through fixed coil L₁, and the other half of the condenser voltage (180° out of phase with the first half) is applied to tube VT₂ through fixed coil L₂. Both the desired voltage due to the main field and the undesired voltage due to the quadrature field are developed across C, so it is necessary to prevent the quadrature voltage from acting upon the grids of the tubes. This is accomplished in the following manner: The voltage induced in an untuned vertical antenna by the main field is made to send a current through a double-rotor inductance (L₃ and L₄) that can be adjusted to induce exactly the required balancing voltage in fixed coils L₁ and L₂. These two balancing voltages cancel the quadrature components in their respective circuits; the only voltages acting on the tube grids are those due to the main field, and consequently the desired figure-eight pattern with sharp minimums is secured.

TAKING BEARINGS

The practice of using the loop antenna in its zero-signal position in radiocompass work means the radiocompass receiver must be extremely sensitive. Not only is the voltage induced in the small rotatable loop quite small, but, in addition, only a small percentage of that voltage (approximately 2%, corresponding to a 1° deviation of the loop from its broadside position) is used in taking a bearing.

The knack of getting good bearings is acquired only after extensive practice. It is possible to get a very narrow null with a modern radiocompass by adjusting the balance control properly.

Even so, there is a region of several degrees in which the signal almost disappears when the r.f. gain of the compass receiver is at a normal setting. If you advance the r.f. gain control, the receiver blocks, flattening the response at maximum pick-up positions, but you don't care about those positions anyway; it is the nulls you are interested in. Next, attempt to center the loop at what appears to be the bottom of the null. This done, vary the balancing control slightly. You will probably find that you can get a deader null. Turn up the gain slightly and vary the direction of the loop a bit either way, and thus "feel around" the depth of the null or "valley." You can probably determine points of equal strength on either side of the "valley" if it is not a good clean null. With

practice, you can then establish the direction within a degree or closer by taking the midpoint of the equal signal points (which should not be over 4 or 5 degrees apart). On a good installation, you should be able to hit the null within a half degree without resorting to equal signal points.

Taking a bearing is not always as easy as the preceding description may have made it sound. It may be very difficult on a stormy night, with static crashing in your ears and the ship rolling and pitching so much that you can hardly stand. Half-degree accuracy is unlikely under such circumstances—indeed, you will probably have to take several bearings and average the ones that agree most closely to come within a few degrees of the right bearing.

Typical Radiocompass Installations

The Radiomarine AR-8709 Radio Direction Finder, shown in Fig. 15, is typical of the units installed in modern ships. Let us study its details.

The entire assembly is mounted from the deck above so that it uses no space on the deck of the compartment in which the direction finder is placed. (In landlubber language, the unit is mounted on the ceiling with the shaft running through the roof to the loop outside, so no floor space is used in the room.)

The receiver proper is in the upper compartment with the compass rose (compass-card) indicator located on the panel just beneath. A handwheel for rotating the loop and the indicator is on a shaft that projects from the bottom of the unit. A brake is located on the shaft housing just above the receiver for locking the loop in one position. The brake knob is turned

clockwise to engage the brake. Additional space is provided in the panel



Courtesy R.M.C.A.

FIG. 15. This man is making a position fix with the R.M.C.A. AR-8709 direction finder.

behind the compass rose for mounting a gyro-repeater motor or Selsyn for controlling the compass rose directly from the gyrocompass. The weight of the entire radiocompass is about 100 pounds, including the loop assembly.

The receiver is a six-tube superheterodyne with an over-all sensitivity of better than 5 microvolts with respect to the actual voltage induced in the loop. The power requirements are 6 volts at 3 amperes for the filament supply and 90 volts at 10 to 20 milliamperes for the B+ supply. A simplified diagram of the receiver is shown in Fig. 16.

The input circuit of the receiver is tuned by inductance L_T , a slug-tuned coil used to align the circuit, and by condenser C_T . Condenser C_T is a section of a three-gang tuning condenser, the other two sections of which are used for the first detector and the oscillator. The entire input circuit is symmetrical about the grounded center-tap of the loop—in other words, only half of the input voltage is applied to the grid of the tube. The cathode is kept at r.f. ground poten-

tial by the by-pass condenser C_c . The loop is shielded so that any small lack of symmetry will not result in vertical or antenna effect.

A "Sense-Balance" switch is incorporated on the balancing condenser in very much the same manner as power switches are located on volume controls in radio receivers. When the balancing condenser is turned to the limit of its clockwise rotation, the sense antenna is connected to one side of the loop, the resulting effect being that the combined antennas have a cardioid reception pattern that can be used to determine the general direction of the transmitting station.

When the balancing condenser is turned back to the main part of its scale, the sense antenna is connected directly to the balancing condenser. Its function is now to balance out the quadrature effect and allow the loop to give a clean figure-eight pattern. This can be done because the sense antenna picks up a field that may be added to either one side or the other of the loop by the small balancing condenser. In other words, if there is

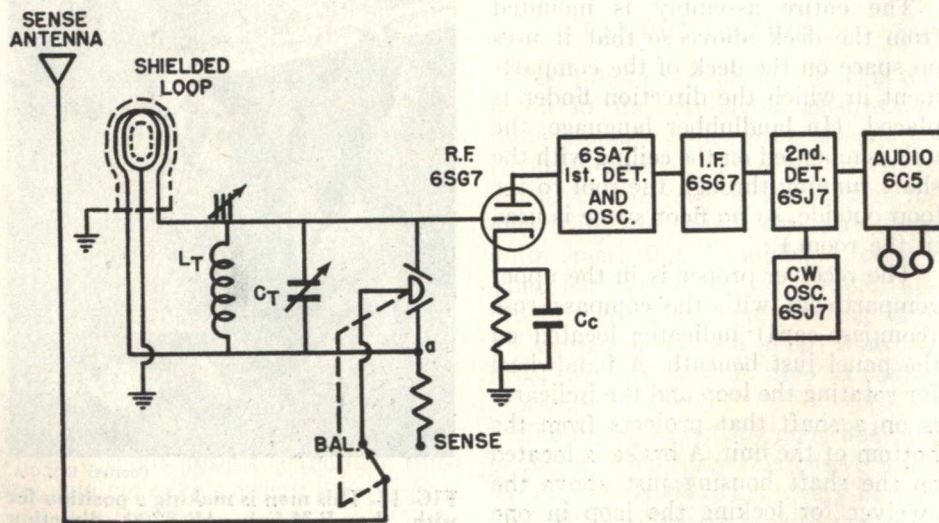

FIG. 16. Simplified diagram of the AR-8709 radiocompass receiver.



Courtesy R.M.C.A.

Typical Marine direction-finder loop. Notice the sturdy housing used to provide shielding and to protect the loop from the weather.

any quadrature effect in the pickup of the loop, the voltage measured from the grid of the tube to ground is not exactly the same as that between point a and ground; the balancing condenser can be used to insert an equal and opposite quadrature voltage in the circuit and thus cancel the undesired voltage. If proper precautions have been taken in the installation, such as adequate clearance from metal structures, no closed paths for radio frequencies nearby, etc., it is possible to secure an extremely sharp null by manipulating the balancing condenser.

The remainder of the receiving circuit is of conventional design and need not be described here. The second beat oscillator (labeled "CW OSC") provides a beat with the intermediate

frequency in the plate of the second detector to give an audible note when c.w. signals are received. To minimize radio interference as much as possible, all radio beacon stations operate in the frequency band between 285 and 400 kc., with 375 kc. being designated as the international radiocompass frequency.

On large ocean-going vessels, the loop for the radiocompass is placed on top of the chart room. A hollow shaft extending downward into the compartment is the means by which the loop is rotated. The leads from the loop pass through the center of this hollow shaft and connect to slip rings that contact stationary brushes. The hand-wheel is connected directly to the shaft. A gear drive couples the pointer on the face of the radiocompass to the loop drive shaft.

There are two scales on the rose on the face of the radiocompass: one shows direction with respect to the heading or bow of the ship; the other is oriented to show direction with respect to true north. If the ship has a gyrocompass, usually a repeater motor of the gyrocompass is installed in the radiocompass to set this scale automatically; otherwise, it must be set by hand to the true-north position each time it is to be used. You can get much more accurate bearings if your radiocompass uses a gyrocompass repeater because your reference scale for true bearings then is never inaccurate to more than one-sixth of a degree.

When a bearing is taken, the loop is rotated for minimum signal and the bearing is read, preferably on the scale that indicates true direction, although, of course, it is possible to take them in reference to the ship's heading. After the reading is taken, the balancing control is turned to the "sense" position and the loop is rotated 90° toward the high end of the azimuth scale. If

doing so causes an increase in signal strength, the loop pointer was originally pointing at the transmitter. A decrease in signal strength indicates the pointer was pointing away from the transmitter.

AUTOMATIC DIRECTION FINDER

Another widely used type of radiocompass is the automatic direction finder (ADF). In this device, the signal from the loop is used to control a motor that rotates the loop. Its action

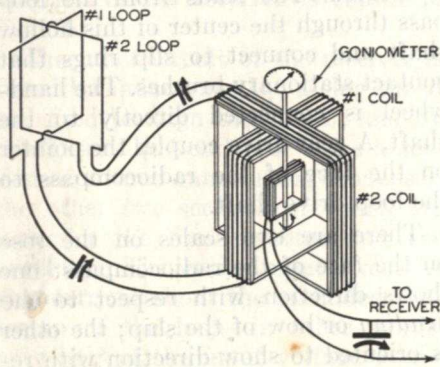

FIG. 17. How the antennas in a Bellini-Tosi radiocompass are connected to the goniometer indicator.

is such that the loop automatically hunts the signal. The device will indicate within a small fraction of a degree the bearing of any signal that is above the noise level. In a variation of this instrument, the loop can be set to any desired course. These units, because of their complexity, cost much more than the standard type of radiocompass, and are not nearly as popular in the marine industry as their simpler and cheaper predecessors. However, they are much used in commercial aircraft.

THE BELLINI-TOSI RADIO COMPASS

Instead of using a rotating loop antenna, the Bellini-Tosi radiocompass

uses two fixed loop antennas mounted at right angles so that some voltage is induced in one or the other of the loops regardless of the direction of arrival of the radio wave. The voltage induced in each loop depends upon the angle between the line from the transmitting station and the planes containing the loops.

The extremities of each loop are connected to coils mounted at right angles to each other, called the *primary coils* of a *goniometer*, as shown in Fig. 17. The primary coils have the same orientation in space as the loop antennas to which they are connected, and they carry the same currents as their respective loop antennas. As a result, these coils produce a local field that duplicates the original field arriving from the transmitter. An *exploring coil*, which rotates in the center of the goniometer primaries, is thus equivalent to a rotating loop and may be used for determining the direction of arrival of the radio waves. A scale attached to the exploring or search coil is graduated from 0 to 360° just as is the scale attached to the conventional rotating loop. The series condensers shown in the figure tune the loop and goniometer primary circuits.

The theory of the Bellini-Tosi system is quite simple. Each loop antenna has a figure-eight characteristic with its maximums along the plane of the loop and its minimums at right angles to this plane. Suppose first that the radio wave arrives in the plane of loop #1. Maximum voltage is induced in this loop and zero voltage in loop #2. Primary coil #1 carries maximum current and primary coil #2 carries zero current. The magnetic field through which the search coil rotates is therefore at a maximum along the axis of coil #1, and maximum voltage will be produced in the search coil when it is parallel to coil #1—that is,

when it is end-on to the direction of arrival of the radio wave.

When the radio wave arrives in the plane of loop #2, coil #2 will carry maximum current and coil #1 will carry zero current. The search coil will have maximum induced voltage when it is parallel to coil #2 or is again end-on to the direction of arrival of the radio wave.

When the radio wave arrives at an angle to both loops, both loops will have voltages induced in them having relative magnitudes that correspond to the angle between the line of motion of the waves and the planes of the loops. Both goniometer coils will carry currents proportional to the voltage induced in their respective loops, and will produce magnetic fields of corresponding intensities. If these fields are in phase (a condition requiring accurate tuning of the loops), their resultant will bear the same relation to the axes of coils #1 and #2 as the direction of the radio wave bears to loops #1 and #2. The exploring coil will therefore again have maximum induced voltage when it is end-on to the direction of arrival of the radio wave.

The chief advantage of the Bellini-Tosi system is that *it permits the use of large fixed antennas with consequent high induced voltages, while retaining the flexibility of the rotating loop.* It is particularly adaptable for fixed station operation on land where loop antennas having base lengths up to 500 feet and heights up to 100 feet are sometimes used. Before the advent of modern radio receivers, Bellini-Tosi installations with large loop antennas were also in wide use on shipboard, particularly on large ships. A considerable number of Bellini-Tosi shipboard installations (practically all on foreign vessels) are still used, but the trend is toward smaller

and smaller loop sizes. An advantage for this system on shipboard is that the goniometer may be located at the receiver, making for simpler use of the radiocompass.

THE ADCOCK RADIOCOMPASS

A serious error arising in the use of radiocompasses, known as night error or polarization error, occurs whenever the radio waves arrive at the receiver by reflection from the heavily ionized layers existing from 70 to 280 miles above the earth's surface. These errors produce swinging of the radio bearing and false bearings, so that accurate use of the loop-type radiocompass under such conditions often becomes nearly impossible. Fortunately, such conditions occur only when the radio wave arriving along the surface of the earth has been attenuated appreciably by distance (i.e., when the receiver is more than about 100 to 200 miles from the transmitter). However, night error does impose a serious limitation on the use of the radiocompass on broadcast frequencies at night or on short waves at all times.

Adcock showed that these errors resulted from stray voltages induced in the horizontal members of the loop antennas by downcoming waves, and devised a vertical antenna system that was not subject to such errors. The Adcock radiocompass system is gradually replacing the Bellini-Tosi system on land station installations.

One form of the Adcock radiocompass is shown in Fig. 18. Vertical antennas 1 and 2, placed on opposite corners of a square, replace one of the loop antennas of the Bellini-Tosi arrangement, and vertical antennas 3 and 4 on the other corners replace the other loop antenna. The two antennas of a pair (such as 1 and 2) are connected by a pair of buried transmission lines that are reversed with re-

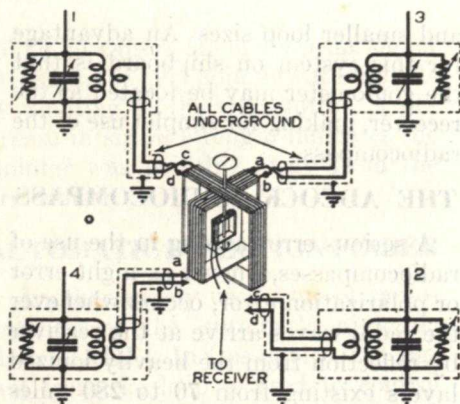

FIG. 18. How the antennas are connected to the goniometer indicator in an Adcock radiocompass.

spect to each other so that the voltages induced in the two antennas oppose each other across the primary goniometer coil. By using these two pairs of vertical antennas, with each pair equivalent to a loop antenna but with no horizontal elements to be affected by the downcoming waves, Adcock eliminated night errors in his radiocompass. In all other respects, the Adcock antenna system is equivalent to the Bellini-Tosi system.

Finding Distance. Most U. S. shore and lightship radio beacon stations are

now equipped to produce synchronized radio and sound signals to aid vessels to determine their distances from the stations at short ranges. This improvement was inaugurated to reduce the number of accidents to lightship stations by ships "homing" on their signals, and to assist mariners in navigating under poor visibility conditions near the coast line.

The transmitting station sends out short radio pulses and, at the same instants of time, short air-foghorn blasts. Since radio waves travel with the speed of light (practically instantaneously), but sound waves have a relatively low velocity (about 1100 feet per second), the time between the receipt of the radio signals and the corresponding sound signals gives the mariner a direct measure of his distance from the source. For example, assume that each sound signal is heard 14.4 seconds after the corresponding radio pulse. The receiving point is then $\frac{14.4 \times 1100}{5280} = 3$ miles from the transmitting source.

A stop-watch or clock with a specially graduated dial is necessary in using this service.

Loran

The radio compass is intended primarily for use when fairly close to the shore (100 miles or so). Before 1942, once a ship was out into the ocean, sun or star observations had to be used to find the ship's position. However, since 1942, many ships have been equipped with loran (from *LONG RANGE Navigation*). This system, which establishes the position of a ship (or airplane) through measurements made aboard ship, can be used over great distances—about 600 to 700 nautical miles during the day, and 1200 to 1400 nautical miles at night. Despite the distance, the accuracy is quite good; even under poor conditions, a Loran fix will seldom be wrong by more than five or ten miles and may be within a half mile when conditions are favorable.

In the loran system, instead of determining the direction from which the signals come, the time difference between signals coming from two different stations is measured. This gives a location along a line, and by making a similar observation on signals from another pair of stations, it is possible to get a position or fix.

LORAN TRANSMITTERS

The basic loran shore installation consists of a pair of stations, called a "master" and a "slave" station. The master station transmits high-power pulses that are about 40 microseconds wide, with an interval between the pulses of about 40,000 microseconds. (A microsecond is one-millionth of a second). The slave station, located several hundred miles from the master station, receives each pulse, and, after a predetermined delay period, transmits a similar pulse on the same frequency.

On board ship, the loran receiver picks up both series of pulses (that from the master and that from the slave), and by using an oscilloscope with a timed sweep, measures the difference between the times of arrival of a pulse from each. This time difference depends on the relative distances between the two stations and the ship.

In other words, the ship receives a pulse from the master station directly. This same pulse must travel to the slave, then after a time delay, the slave transmits a similar pulse that must travel to the ship. Since both pulses travel through space at the same rate of speed, the time difference between the receipt of the two pulses is a measure of the location of the ship with respect to the two stations. The closer the ship is to the slave station, the shorter the time difference, because the ship receives the master pulse at about the same time that the slave station does. On the other hand, the closer the ship is to the master station, the longer the time interval, because the master pulse must travel all the way to the slave station and the slave pulse must travel back before the ship can receive it.

The time difference between signals from a single pair of stations will not give the exact position; it gives only a location along a line. In other words, a line can be drawn, on which at every point there will be the same time difference in receipt of the two signals.

Thus in Fig. 19A, there will be a certain time difference at W between the signals from M and S. At points X and Y, the same time difference will be found because the paths for both signals are increased equally. This establishes the line P-P for a particular time difference, and the ship whose

loran receiver is indicating this difference can be anywhere along this line.

In Fig. 19B, the position T is closer to S than was W in Fig. 19A, so this point is one for another time difference. Points U and V, also have this new time difference, thus establishing a new line R-R.

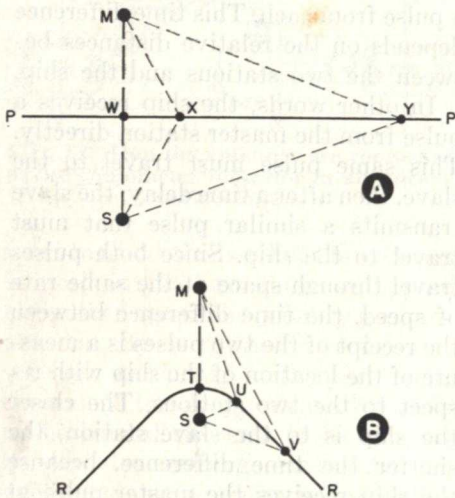

FIG. 19. The time difference along any one line-of-position remains the same.

For each pair of loran stations, navigational charts like those shown in Fig. 20 are furnished. These lines are superimposed over a regular map, and they are called loran lines-of-position. The numbers on them indicate time differences in microseconds. Thus, a navigator who finds that he receives a pulse from the slave station 2200 microseconds after he receives one from the master station must be somewhere on the line of position marked 2200. Since he may be anywhere on this line, he must find a second line of position by obtaining readings from another pair of loran stations. The point where the two lines-of-position cross is then his actual location.

Many installations, instead of having four stations to give the two sets of

lines-of-position, have a single master that excites two slave stations. The master is double-pulsed; that is, it transmits two distinct series of pulses, each of which is paired with one of the slave stations. The two series of pulses from the master are completely independent of one another, and for all practical purposes can be considered as coming from two different stations.

The master and any one slave transmit identical pulses, at the same rate and with the same timing. Any other nearby loran pair must use a different pulse rate or timing interval, because loran stations do not transmit identifying letters. They must be identified by a combination of the frequency on which they are received and the pulse repetition rate. There are four loran channels: channel 1 is 1950 kc; channel 2 is 1850 kc; channel 3 is 1900 kc; and channel 4 is 1750 kc.

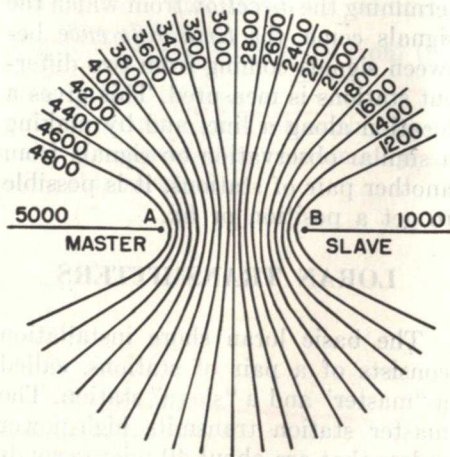
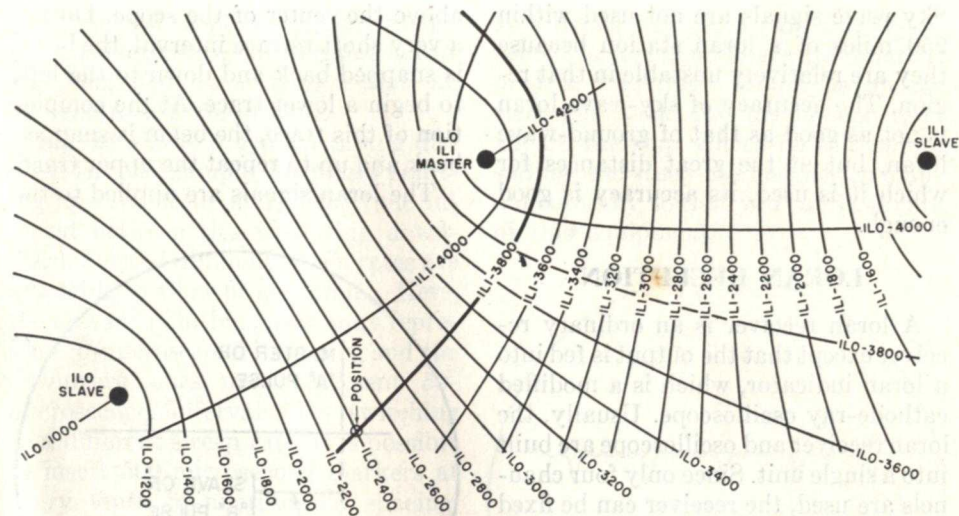

FIG. 20. A typical system of loran lines-of-position.

There are two basic pulse repetition rates, 25 pulses per second and 33-1/3 pulses per second. These basic rates are subdivided into what are termed specific rates, increasing the basic rates in steps of about 1/16 pulse per sec-



This shows how the loran lines from two pairs of stations overlap to be useful in finding a position. For example, if the navigator gets a reading of 3800 from the ILI pair, he is somewhere along this line (shown heavy). When he switches to the ILO pair, his reading determines his position along the ILI-3800 line. Thus, if he gets a reading of 2400, he is at the point where the ILO-2400 line crosses the ILI-3800 line.

ond, so that the low pulse rate ranges from 25 to 25-7/16 pulses per second and the high rate from 33-1/3 to 34-1/9 pulses per second.

On a loran chart, the lines of position for each pair of stations are identified by a three-character symbol preceding the time-difference figure. The first character of this symbol indicates the channel, the second gives the basic pulse-recurrence rate, and the third gives the specific pulse-recurrence rate. Thus, a line marked 2L4-2200 indicates that the pulses, which occur at a 2200-microsecond time difference, are coming from a pair of stations operating on Channel 2 at the basic "low" pulse rate L, and the specific rate 4 (25-4/16 pulses per second). The navigator, of course, uses these symbols the other way: he determines the channel and the pulse rate, adjusts his receiver accordingly, and after determining the time difference, looks up the corresponding line-of-position on his map.

Standard loran operates on ground-wave radiation, and loran charts are computed on that basis. This sets the useful range at about 700 miles during the day and 450 miles at night. The night range is lower because of the external noise level. However, sky-wave signals are sufficiently reliable at night to be used for loran reception, extending the useful range to about 1400 nautical miles. The signals used are those that are reflected once from the E layer of the ionosphere, and are therefore known as "one-hop E" signals. Because they travel over a longer path, these sky-wave signals are slower to reach a given point than are ground-wave signals. If the transmission between the master and slave is on ground waves, sky-wave signals can be used by adding a correction to the time-difference measured. This correction, which takes into account the longer traveling time of sky waves, is entered on loran charts beside the lines of position with which they are used.

Sky wave signals are not used within 250 miles of a loran station because they are relatively unstable in that region. The accuracy of sky-wave loran is not as good as that of ground-wave loran, but at the great distances for which it is used, its accuracy is good enough.

LORAN RECEPTION

A loran receiver is an ordinary receiver except that the output is fed into a loran indicator, which is a modified cathode-ray oscilloscope. Usually, the loran receiver and oscilloscope are built into a single unit. Since only four channels are used, the receiver can be fixed tuned to these channels, and a selector switch can be used to select the desired channel.

The oscilloscope controls are simplified—there is a low and high basic

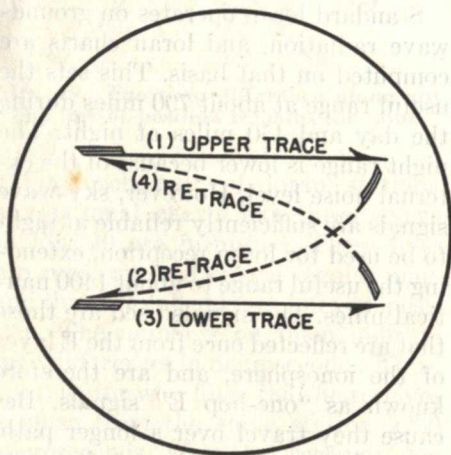

FIG. 21. This is how the traces on a loran scope are produced.

pulse rate switch and a selector, which selects the specific rate from among the eight associated with either the low or the high rates.

The oscilloscope tracing pattern is that shown in Fig. 21. For half the trace, an upper-trace line is drawn

above the center of the scope. During a very short retrace interval, the beam is snapped back and down to the left, to begin a lower trace. At the completion of this trace, the beam is snapped back and up to repeat the upper trace.

The loran signals are applied to the

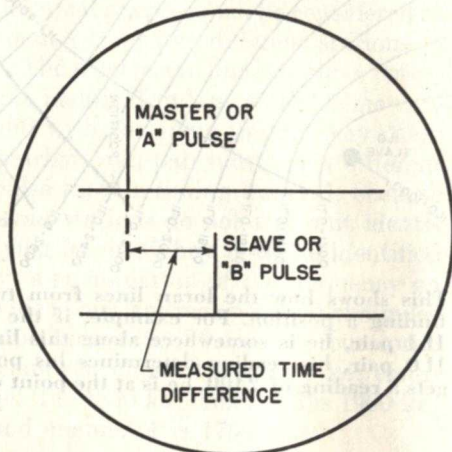

FIG. 22. This is a simplified representation of the picture formed on a loran scope by pulses from a master and a slave station.

vertical deflection plates of the scope and thus produce vertical deflections in the traces. A simplified representation of the scope picture is shown in Fig. 22. The master pulse produces a line on the upper trace while the slave pulse produces one on the lower trace. Since the slave station automatically introduces a delay of half the pulse recurrence interval, we can determine the time difference between the signals by measuring the difference between their spacings as shown in Fig. 22. This reduces the time difference to a scale that is simpler to handle.

Of course, it is necessary to measure the time difference, not the horizontal distance; therefore some method must be used to convert this distance into microseconds. To make this easier, timing pulses are fed to the vertical

plates of the scope at regular, predetermined intervals, thus forming markers along the horizontal trace that can be used as a scale of time.

Fig. 23 shows a typical timing display. In this example, the pulses pointing upward occur at 1/5 the time interval between those pointing downward. Several different sweep rates are available to allow proper timing. Here, the upward pointing pulses may represent 10-microsecond intervals, and the downward ones may represent 50-microsecond intervals. By switching to a different sweep rate, it is possible to insert 500-microsecond markers at every tenth 50-microsecond spacing, and even to put in 2500-microsecond markers at every fourth 500-microsecond position.

The loran receiver is considered a navigational device, so it is located on the bridge of the ship for the convenience of the navigator, instead of in the radio room. Ordinarily, the navigator operates it. However, if anything

goes wrong, the radio man will be expected to repair it. There are different models, and there should be an instruction book for the model used aboard the ship. Check on this before sailing, and study the instruction manual carefully so that you can take care of this equipment.

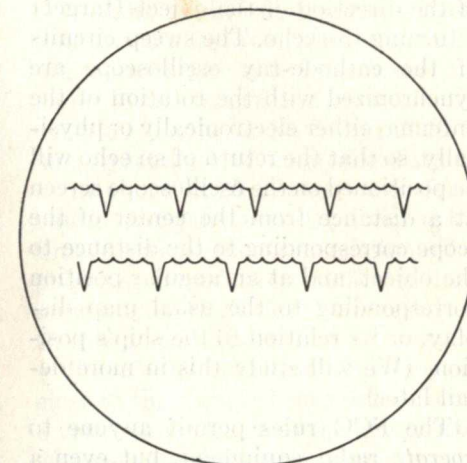

FIG. 23. Timing markers as seen on a loran indicator.

Radar

Radar is another navigational aid that is finding more and more use on ships and airplanes. Radar (from *R*adio *D*etection *A*nd *R*anging) is not used to determine the position of a ship as much as it is to show surrounding navigational hazards, such as other ships, icebergs, etc. However, since it does give rather complete details of the surroundings, it can be used to find the position with relation to known surroundings in, say, a harbor, where it can be used to "see" all surrounding objects—other ships, buoys, docks, etc.

A radar assembly is a combination of a transmitter and a receiver using

a common antenna system. Extremely sharp pulses are sent out; these strike surrounding objects and are reflected back to the antenna. The receiver is equipped with a cathode-ray oscilloscope arranged to indicate the time difference between the transmission of a pulse and the return of its echo. Since radio waves travel at a known velocity, the time taken for the round trip of the pulse is a measure of the distance of the object from the ship.

The direction of the object from the ship is determined by using a rotating, highly directive antenna, and a rotating cro display system. This allows pulses to be sent so that one travels

straight north, the next a little to the east of north, the next a little more east, etc. The antenna rotates slowly with respect to the pulse rate, so pulses have time to travel to the reception horizon and back before the antenna position changes appreciably. Thus, the position of the antenna when it receives an echo signal is an indication of the direction of the object (target) returning the echo. The sweep circuits of the cathode-ray oscilloscope are synchronized with the rotation of the antenna, either electronically or physically, so that the return of an echo will be positioned on the oscilloscope screen at a distance from the center of the scope corresponding to the distance to the object, and at an angular position corresponding to the usual map display, or its relation to the ship's position. (We will study this in more detail later).

The FCC rules permit anyone to operate radar equipment, but even a licensed radio operator is not permitted to repair or adjust radar equipment *unless he has a radar endorsement on his operating license*. Any operator holding a first or second class radio telegraph or telephone operator's license may obtain this endorsement by passing an examination on Element 8. This is a special FCC examination containing sixty-nine questions, fifty of which will be asked the person taking the examination.

All adjustments and tests made during the installation and maintenance of radar equipment must be performed under the supervision of the person holding a license with this radar endorsement. Persons not holding such a license may only replace fuses or tubes in the receiver—they may not make any other servicing adjustment.

The following description covers many of the questions in the FCC examination. The remainder of Element

8 can be answered after you study microwave transmitters in later lessons.

RADAR REQUIREMENTS

The transmitter must send a pulse, then must remain off while the receiver "listens" for the echo.

Since radio waves travel at a very high speed, it is necessary that the transmitted pulse be of extremely short duration if nearby objects are to be indicated, because the transmitter must cease before the receiver goes into operation. Pulses may be only from $\frac{1}{2}$ to 2 microseconds long for a 3 to 10 mile range.

Since the antenna is rotating and thus scanning in a new direction all the time, there must be enough pulses per second to cover all points of the compass adequately. Shipboard radar pulse rates are usually between 1000 and 2000 per second. At a rate of 2000 pulses per second, the time from the start of one pulse to the start of the next is 500 microseconds (only .0005 second, since a microsecond is one millionth of a second).

To have sufficient power to get back enough echo signal to operate a relatively insensitive receiver, it is necessary to concentrate quite a bit of power into each narrow pulse. Peak power levels run around 30 kilowatts, but can run as high as 300 kilowatts in some installations.

Even with such high peak powers, the average power is surprisingly low because the time "off" is so much longer than the time during which the pulse is sent. The formula is

$$P_a = P_p \times PRR \times W_p$$

where P_a is the average power in watts, P_p is the peak power, PRR is the pulse repetition rate, and W_p is the width of the pulse in seconds. For example, let's suppose you have a peak power of 50 kilowatts, a repetition rate of

1200 per second, and that each pulse is 1 microsecond wide. This figures out to be

$$P_a = 50,000 \times 1200 \times .000001 \\ = 60 \text{ watts}$$

In other words, although the average power is quite low—in fact rather small when compared to most transmitter powers, the peak power during the pulse is extremely high. The actual peak power depends upon the distance the radar unit is to cover and on the width of the pulse. The narrower the pulse, and the greater the distance, the higher the peak power must be.

To have an antenna system of reasonably small size, and to get a large reflection from small objects, very high frequencies must be used. The ship service bands are: 2900 to 3300 mc, 5250 to 5650 mc, and 8500 to 9800 mc. These are known respectively as the 10, 6, and 3 centimeter bands. Such high frequencies and the high peak powers require special transmitter and receiver design.

As you know, radio waves travel at 186,000 miles per second. Incidentally, this is statute or land miles, and distances at sea are figured in nautical miles. At the rate of 186,000 miles per second, in one microsecond, a radio wave will travel .186 land mile or .162 nautical mile. (The ratio of land miles to nautical miles is 1760 to 2027).

Looking at this another way, if the target is 1 mile from the radar set, a radio wave will travel from the antenna to the target and back (1 mile out plus 1 mile back) in about 10.75 microseconds for a land mile distance or in about 12.25 microseconds for a nautical mile distance. By dividing the time between the transmission of a pulse and its return by 10.75 (for land miles) or by 12.25 (for nautical miles), the distance in miles may be found.

Therefore, to detect objects very close to the ship, it is necessary to use a very narrow pulse so the transmitter will be cut off by the time the echo returns, and it is necessary to use a

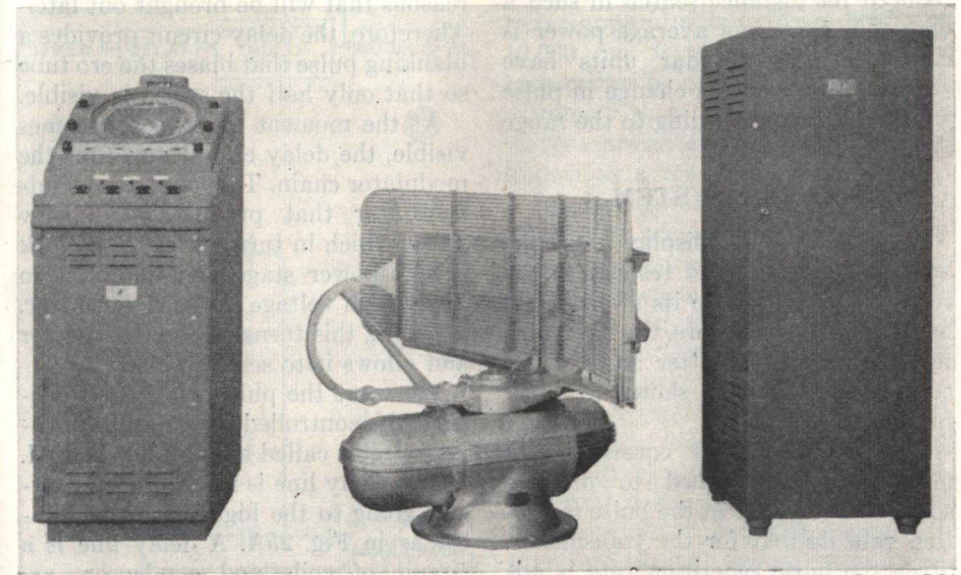

The three chief components of the RCA C101 radar unit designed for use in surface ships. Left, the indicator unit; center, the rotating antenna assembly; right, the transmitter-receiver.

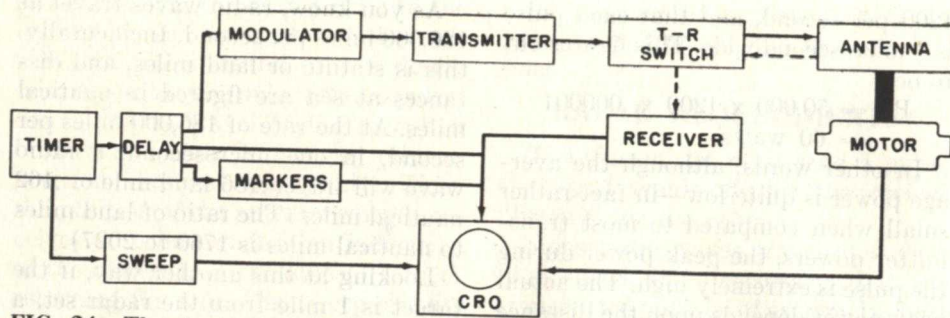

FIG. 24. The timer controls the sweep and a delay circuit. The delay blanks half the sweep trace, and operates the marker and modulator circuits. When the modulator applies a pulse to the transmitter, the signal passes through the T-R switch to the antenna. The echo returns from the antenna through the T-R switch to the receiver. Each echo causes a "blob" to appear on the CRO tube. The sweep is rotated by a tie to the motor rotating the antenna.

high pulse repetition rate because the transmitted beam is very narrow as it leaves the antenna.

When objects are at a greater distance, broader pulses are permissible, and since they are easier to form, it is desirable to use them. Also, the radio wave "spreads" as it travels, so each pulse covers a wider area. This allows the pulses to be broadened and the rate reduced for distance search in such a way that the same average power is consumed. Most radar units have switches to make this change in pulse width and rate according to the range desired.

RADAR SYSTEM

The oscilloscope display must be accurately timed with respect to the transmitted pulses, so its sweep must be controlled. Therefore, the basic unit for both the transmitter and the receiver is a timer, as shown in block form in Fig. 24.

The timing circuit consists of a multivibrator, designed to produce square wave pulses at the pulse repetition rate desired for the transmitter. Since the pulse repetition rate is adjustable, the resistors and condensers in the multivibrator are connected to a switch assembly so that the proper

ones may be inserted for the rate desired.

The timer output is used to control the sweep for the oscilloscope, and also operates a delay circuit that affects the cro display and drives the modulator.

The sweep would cause a line to extend across the cro tube face from edge to edge. We only want the sweep to be visible from the center to one edge, for reasons that will be brought out later. Therefore, the delay circuit provides a blanking pulse that biases the cro tube so that only half the sweep is visible.

At the moment the sweep becomes visible, the delay circuit also fires the modulator chain. This operates a multivibrator that produces a narrow pulse, which in turn serves to unblock a high-power stage and allows it to apply high voltage to the rf generator. In effect, this turns on the transmitter and allows it to send a pulse.

We want the pulse width to be accurately controlled, so another "timing" circuit called a delay line is used.

The delay line is inserted in the circuit going to the high-power modulator as in Fig. 25A. A delay line is a circuit of coils and condensers arranged as in Fig. 25B so that a wave or signal must travel along it in a progressive fashion. It has a time constant

—it takes a definite length of time for energy entering the line to reach its end. If the end of the line is not terminated by a load equal to the impedance of the line, the energy that travels down the line will be returned to its sending end, but will be out of phase with the energy that originally went into the line. Since it takes a definite length of time for energy to travel down the line and back, by arranging the length of the line properly, it is possible to get back an out-of-phase signal that is timed very accurately. Therefore, when the multivibrator turns on the modulator, it introduces energy into the delay line at the same time. At a pre-determined time, this energy is returned, now out of phase, so that it cuts off the modulator. Thus, the pulse width is determined quite accurately.

In Fig. 25B, the switch SW adds

additional sections to the line so that, when a wider pulse is desired, more sections can be used so that it takes a longer time for the wave to travel to the end of the line and back.

The delay circuit (operated from the timer) controls another timing stage consisting of a group of R-C time constant units. These feed timed pulses into the cro so as to produce "marks" on the tube face at points corresponding to known distances. These bright points produced on each cycle of the sweep blend together so that rings are drawn on the cro tube face, thus making it possible to judge more accurately the distance from the ships to objects producing echoes.

Thus, if the range is set at, let us say, 1½ miles, there will be range markers for each half mile. If the range is set at 50 miles, there may be range markers for each 10 miles, etc.

THE TRANSMITTER

Since the transmitted signal from a radar apparatus is between 3000 and 10,000 mc, it is necessary that the transmitter be of special design. Such extremely short waves—called microwaves—are generated in a special tube known as a magnetron.

In the ordinary transmitter with which you are familiar, a master oscillator produces a carrier frequency which is then amplified by a number of stages. In radar, the magnetron produces the carrier at full strength; there is no amplification.

Another radical difference is that, at such very high frequencies, there is too much loss in a transmission line to permit its use. The coupling between the transmitter and the antenna is therefore through waveguides. In effect, the magnetron current produces an electromagnetic field within the tube itself. Then, pipes are used to

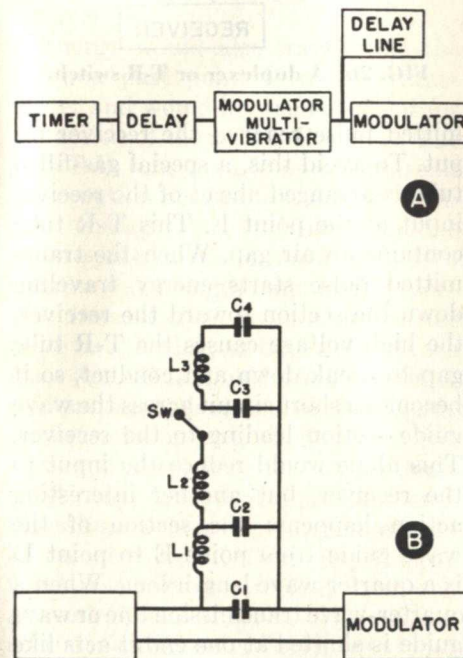

FIG. 25. How a delay line is inserted in the modulator chain to determine the pulse length.

carry this energy from the magnetron to the point of radiation. In other words, instead of there being an rf current flowing in a transmission line between the final stage and an antenna, the radio waves are produced in the final stage, and they are guided through a pipe to the point at which they are emitted. At the "antenna," the energy sprays out from the end of the wave guide. It strikes a reflector that directs it in the direction we want it to go.

Magnetrons and wave guides will be studied in detail in later Lessons when you take up microwaves. This subject is so different from that of ordinary radio transmission that several Lessons are needed to cover it fully. For now, just consider the transmitter to be fundamentally like any other in that it is a source of rf energy. The radio wave travels down the wave guide just as a current travels along a transmission line. At the "antenna" the energy escapes into space just as from any regular antenna system.

THE T-R SWITCH

When the echo signal is intercepted by the reflector, it is directed, still as a radio wave, into the mouth of the waveguide; then it follows this pipe back to the receiver. Since both the transmitter and the receiver use the same antenna system, it is necessary to protect the receiver when the transmitter is on. Because of the extremely short time intervals, a special electronic circuit known as a T-R (transmit-receive) switch or duplexer is used. This device automatically connects the transmitter to the antenna and disables the receiver input while the transmitter is on. As soon as the transmitter cuts off, the antenna is switched to the receiver.

The T-R switch makes use of the fact that sections of a waveguide act

like corresponding lengths of transmission line. Fig. 26 shows a schematic of a commonly used system. The main wave guide is a hollow pipe running from the transmitter to the antenna. Attached to this pipe at point D is another pipe going to the input of the receiver. When the transmitting pulse travels down the wave guide, the receiver input would be overloaded and the input circuits ruined if the trans-

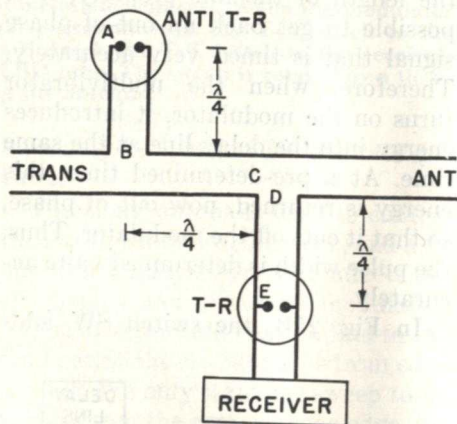

FIG. 26. A duplexer or T-R switch.

mitted pulse reached the receiver input. To avoid this, a special gas-filled tube is arranged ahead of the receiver input at the point E. This T-R tube contains an air gap. When the transmitted pulse starts energy traveling down the section toward the receiver, the high voltage causes the T-R tube gap to break down and conduct, so it becomes a short circuit across the waveguide section leading to the receiver. This alone would reduce the input to the receiver, but another interesting action happens: the section of the waveguide from point E to point D is a quarter wave length long. When a quarter-wave transmission line or waveguide is shorted at one end it acts like an open circuit (high impedance) at the other end. Therefore, the waveguide section appears at point D to

be a high impedance circuit so that very little energy passes in the direction of the receiver.

When the transmitted pulse is traveling down the wave guide, another section known as the anti T-R section is also actuated. The anti T-R tube at point A shorts a quarter wave line to cause it to act as an open circuit at B, so that little energy is extracted here. This has nothing to do with the transmission, but this tube action is important on reception.

When the transmitter pulse has been radiated and the transmitter is cut off, both the T-R and the anti T-R tubes stop conducting. The system is now ready for reception. When a pulse is returned from the antenna, it is of low energy, and cannot fire the T-R tube. Therefore, energy will travel from the antenna to the point D, and from there through the open gap at E to the receiver.

Energy would also travel from the antenna past point C to the transmitter and would be wasted except for the action of the anti T-R circuit. The anti T-R tube at A is an open circuit on reception because there is not sufficient energy to fire it. Notice that the waveguide section from A to B is a quarter wave length long, and the section from B to C is another quarter wave length long, so that the distance from A to C is a half wave length. A half wave length section of waveguide or transmission line, when open at one end, appears to be an open circuit (high impedance) at the other end. Therefore, at point C, there appears to be an open circuit (high impedance) insofar as energy returning from the antenna is concerned. For this reason, all the received energy is diverted into D to the receiver, and practically none is wasted in the transmitter.

Therefore, by using quarter wave

sections and arranging an automatic short circuit that will go into action when the transmitter is on, but not be present when energy is being received, it is possible to arrange for practically all the transmitted energy to go to the antenna and practically none to the receiver, and for practically all the received energy to come from the antenna to the receiver with practically none wasted in the transmitter. This action is entirely automatic—the T-R tubes operate as soon as the voltage gets above the level that will arc between the contact points within these tubes.

Most T-R tubes have a "keep alive" circuit. This consists of another terminal and a dc voltage source between this terminal and one of the firing terminals. As a result of this dc voltage, there is a slight condition of ionization so that the tubes will fire at a lower voltage than the gap spacing would ordinarily permit. This makes them more sensitive—they fire more quickly at the start of the transmitter pulse and therefore serve to protect the receiver more definitely. However, with age, these tubes lose their effectiveness, because as a result of the more or less constant ionization some of the gas combines with the electrodes. This reduces the sensitivity.

The T-R tube is checked by measuring the voltage drop across an external resistor through which the keep-alive electrode current flows. When this voltage drop falls outside the recommended limits, the T-R tube should be replaced.

The anti T-R tube does not use a keep-alive electrode and is less critical about its operation. Generally, however, it is replaced about every 1000 hours of operation.

THE RECEIVER

The incoming signal is extracted

from the waveguide by a pickup coil, and passes directly to a crystal rectifier, along with a signal from the local oscillator. A crystal is used as a mixer because it produces less converter noise and allows a simplified input circuit. The local oscillator is a special microwave tube—usually a Klystron, which you will also study in a later

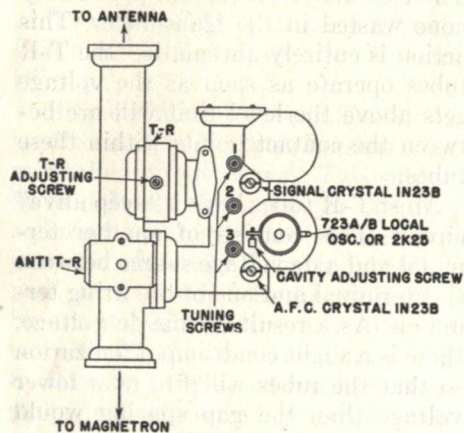

FIG. 27. A drawing of a T-R assembly and the receiver input.

Lesson. However, it functions as a local oscillator, as in any standard superheterodyne receiver.

After mixing, the signal is amplified by an i-f amplifier. After detection, the signal is amplified by broad-band amplifiers similar to the video amplifiers found in television receivers, then it is fed to the oscilloscope. Basically, therefore, the receiver is just a standard superheterodyne with the exception that the local oscillator and input circuits are especially designed for the very high frequencies used, and the i-f amplifier frequency is high.

The local oscillator frequency drifts, so it is controlled by an afc network. This network compares the local oscillator and the transmitted signals to extract a control voltage that will pull the local oscillator to a frequency that causes the correct i-f to be produced.

Fig. 27 shows how the receiver input is attached to the waveguide. The signal comes through the T-R box to the signal crystal, where it is mixed with the local oscillator signal. For the afc circuit, there is another connection to the waveguide so that a small portion of the transmitted pulse can reach the afc crystal. This path contains a series of baffles with tiny slots, arranged to reduce the strength of the pulse to a level satisfactory for the afc circuit. The afc circuit contains a rectifier and produces an i-f frequency, which is fed to a frequency-discriminating circuit. The output of this circuit is used to control the frequency of the local oscillator to keep it accurately above the transmitter frequency by the desired i-f frequency. The i-f frequency that may be used in radar equipment ranges from 15 to 60 mc, with 30 mc commonly used.

THE ANTENNA

As mentioned before, the radiator (the end of the wave guide) and the reflector, which serves to direct the energy in the desired direction, must



Typical radar antenna installation.

be mounted as high as possible and as free of obstructions as possible.

The motor that rotates the reflector is mounted directly under it, and operates from the ship's power supply. It turns the assembly at about 12 revolutions per minute. Read the maintenance instructions carefully when you go aboard ship, and check to see that this motor is properly lubricated.

The wave guide to the radiator must have an interior surface with as high a degree of conductivity as possible. In many installations, the inside surface of the wave guide will be silver-plated, and that in turn will be plated by a non-tarnishing metal such as gold. Of course, both layers are extremely thin, but their presence assists in delivering maximum energy to and from the antenna.

The end of the wave guide that faces the reflector would normally just be an open end of the pipe. However, it is desirable to keep moisture out of the wave guide assembly, so the end usually has a plastic cover. It is important that no one be allowed to paint this plastic cover while painting any of the rest of the assembly; otherwise the radio waves cannot get out of the wave guide. If the wave guide could be completely sealed, moisture could be kept out of it by filling it with gas, but this usually is not practical. Therefore, the wave guide is closed as tightly as possible. No long horizontal sections are made absolutely level; they have a slight grade toward a low point where there is a drain hole to allow moisture to escape.

THE OSCILLOSCOPE

Let us turn now to the cathode ray oscilloscope. A display is wanted of the ship's surroundings, so the sweep is blanked so that it apparently starts at the center of the screen. The ship's

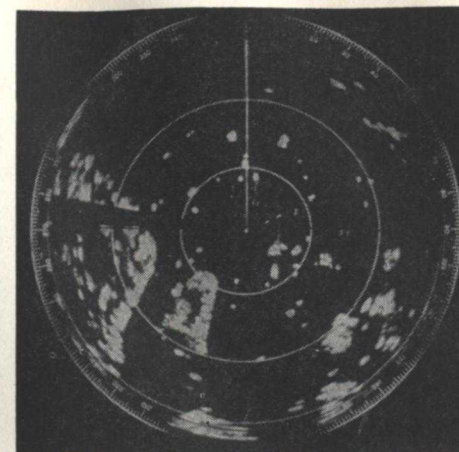

FIG. 28. A typical radar cro display.

position is at the sweep origin (center of the screen).

Fig. 28 shows a typical scope display. At the moment of the photograph, the trace is from the center to the top of the scope. To show the surroundings, the trace must rotate in step with the antenna rotation.

In other words, instead of having just a single-line trace from left to right as is usual for oscilloscopes, and instead of having a rectangular raster as for television, we have a single line trace that apparently rotates around the face of the tube. That is, as in Fig. 29, the sweep forms one trace from the center of the tube to the edge, as at A. A few pulses later, the trace has moved to the position at B, etc.

The position of the sweep line is used as an indicator of the direction of the target. On board ship, the sweep trace position that is straight up on the face of the cro tube represents the front of the ship. Then, a trace from the center to the bottom of the cro tube face is to the rear, etc. The position of the echo spot with respect to the cro screen center therefore indicates the direction of the target with respect to the ship, so the rotation of the sweep trace allows the direction to be determined.

CRT has less fluorescence than TV + more phosphorescence
for more persistence of image (about 10 sec) than trace in

To determine the distance, we take time into consideration. The closer the echo flash is to the center of the face of the tube, the closer the object is to the ship. To mark off distances, time delay circuits cause momentary flashes in each trace. If the trace were to stand still as shown in D of Fig. 29, there would be bright spots along it corresponding to pre-determined distances. However, the trace rotates so that the trace is in a new position for each pulse. Thus, a few seconds later it is at position E. Because of the brightness of the spots, they tend to merge together to form circular traces so that as the sweep rotates around a complete circle as shown in F, it leaves behind it circular traces corresponding to distance.

The radar display in Fig. 28 shows two 1/2 mile circle rings. Each "blob" of light on the face of the tube represents an object that returned an echo. This particular display happens to be that obtained from a ship in New York harbor. The lighted areas represent land, and the smaller spots represent ships, buoys, etc. Indications from the center of the tube face to the first circle are within 1/2 mile of the ship, those between the two circles are 1/2 to 1 mile from the ship, and those between the outer circle and the rim of the face are

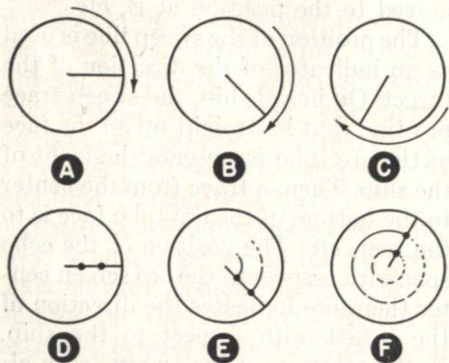

FIG. 29. How the trace moves in a circle around the radar cro tube face.

from 1 mile to 1 1/2 miles from the ship.

When the ship is at sea, waves cause echoes—in a heavy sea the waves light up quite an area on the face of the tube and may obscure dangerous objects ahead of the ship. Under such conditions, when radar is most needed because visibility is so low, the sensitivity of the receiver is adjusted to reduce the amount of light produced by such sea returns as much as possible, and a time-constant circuit is used to chop up the sea return into smaller segments so as to reduce the large lighted areas.

A similar condition exists during heavy rain or snow storms because water drops in the atmosphere reflect radar waves and produce a similar smear in the direction in which the storm exists. This too can be chopped up somewhat by a fast discharge circuit. Incidentally, the ability of a radar set to indicate a storm is useful at sea, particularly when set for long range (50 miles). The extent and direction of the storm can be determined by observation of the oscilloscope.

There are two methods of obtaining the rotation of the sweep trace. One is electronic. This involves four coils arranged around the neck of the cathode-ray tube as in Fig. 30. By exciting these coils from a sine-wave source that is synchronized with the antenna rotation, it is possible to get a field in addition to the one set up by the sweep voltage of such a nature as to cause the sweep trace to rotate.

Another method utilizes direct mechanical coupling as shown in Fig. 31. Here, the field coil producing the sweep is rotated physically in step with the antenna rotation. The synchro transmitter and synchro motor both resemble ordinary motors except that they have two fields. The armatures and the fields of the two units are electrically connected, and the armatures are excited. As the armature of

the synchro transmitter unit is rotated, its magnetic field changes position with respect to the two sets of field coils in such a way as to induce in them voltages that are transferred to the motor unit. This field excitation causes the synchro motor armature to rotate

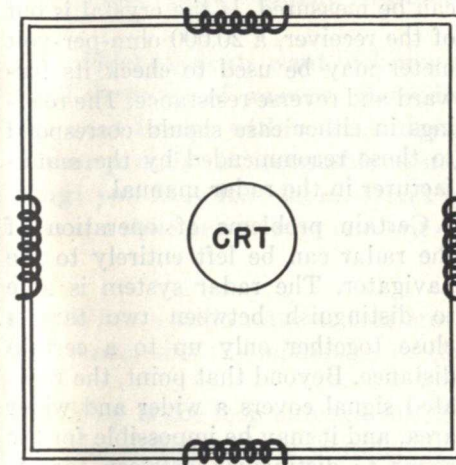

FIG. 30. How a double set of deflection coils may be arranged to give a rotating trace.

to approximately the same position as the armature of the transmitter so as to restore the original field balance within itself. In other words, the two units are self synchronizing so that rotation of one will produce a corresponding rotation in the other. Therefore, as the drive motor turns the antenna system, the synchro transmitter causes the synchro motor to rotate to the same degree and thus to turn the deflection yoke in step with the antenna rotation.

RADAR INTERFERENCE

The radar system is quite valuable and is being used much more widely as time passes. However, it can cause interference with the radio equipment aboard ship, and it is necessary for it to be installed properly to keep this at a minimum. It is particularly impor-

tant that there be no interference in the frequency bands between 100 and 200 kc, 350 and 515 kc, 1850 and 1950 kc, and 2 to 30 mc.

Certain conditions may cause interference to develop, and as a radio man, you may be called upon to eliminate it. Several kinds of interference may develop. A steady tone will be heard in receivers at the frequency of the repetition rate of the pulses, and the antenna drive and synchro motors may cause noise because of arcing at the commutators. This noise may affect the auto alarm, just as heavy static will, causing the warning lights to go on.

The interference may affect the di-

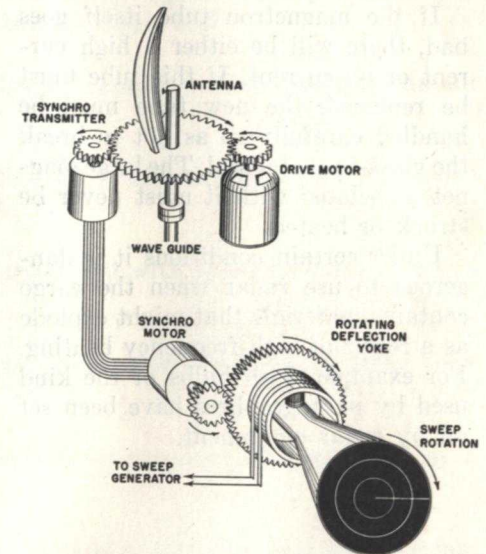

FIG. 31. A mechanical way of getting the sweep trace to rotate in step with the antenna rotation.

rection finder and may cause spurious responses to show up on a loran indicator.

To keep interference at a minimum, it is quite important for the grounds on the shielded lines between the modulator and the magnetron to be kept in good condition, and for the

filters in the power leads to be properly installed and grounded. The entire radar assembly should be grounded carefully to the ship's electrical ground.

DEFECTS

Defects in the radar assembly may be corrected by following instructions in the instruction manual.

A common indication of trouble is a series of flashes over a section of the face of the oscilloscope, shaped like a cut of pie. This condition may be caused by failure of the receiver ave, failure of the magnetron to operate reliably, a frequency shift in the magnetron, or by a poorly shaped square-wave modulator pulse.

If the magnetron tube itself goes bad, there will be either a high current or no current. If this tube must be replaced, the new tube must be handled carefully so as not to break the glass-to-metal seal. The large magnet associated with it must never be struck or heated.

Under certain conditions it is dangerous to use radar when the cargo contains materials that might explode as a result of high-frequency heating. For example, flash bulbs of the kind used by photographers have been set off by radar equipment.

The crystals used in the receiver as the mixer-detector and for the afc circuit are easily destroyed by strong static pulses. A defective crystal will cause the signal to be weak or the receiver to be dead. To facilitate testing, the crystal circuits are brought out to terminals where the crystal current can be measured. If the crystal is out of the receiver, a 20,000 ohm-per-volt meter may be used to check its forward and reverse resistance. The readings in either case should correspond to those recommended by the manufacturer in the radar manual.

Certain problems of operation of the radar can be left entirely to the navigator. The radar system is able to distinguish between two targets close together only up to a certain distance. Beyond that point, the radiated signal covers a wider and wider area, and it may be impossible for the radar to distinguish between targets both of which return an echo at the same time from approximately the same distance. Also, a nearby large target such as the side of a large ship may return several echoes because the wave is bounced back and forth between the ships. None of these conditions indicate any trouble with the radar equipment—they are natural.

Lesson Questions

Be sure to number your Answer Sheet 54RC-1.

Place your Student Number on every Answer Sheet.

Most students want to know their grade as soon as possible, so they mail their set of answers immediately. Others, knowing they will finish the next Lesson within a few days, send in two sets of answers at a time. Either practice is acceptable to us. However, don't hold your answers too long; you may lose them. Don't hold answers to send in more than two sets at a time or you may run out of lessons before new ones can reach you.

1. When a radio wave arrives broadside to the loop, is the loop current: (1) *maximum*; (2) *minimum*; or (3) *half of maximum*?
2. Why is the loop antenna rotated for a minimum rather than a maximum signal when taking bearings?
3. When set for unilateral response, does a loop direction finder have: (1) *one minimum*; or (2) *two minimums*?
4. Why are loop antennas that are associated with direction finders metallicly shielded?
5. Why can loran signals be received at greater distances at night than during the day?
6. Can a ship's position be determined from the lines of position from a single pair of loran stations?
7. If the interval between transmission of a radar pulse and its reception as an echo is 32 microseconds, is the approximate distance in *nautical miles* from the ship to the target: (1) *.26 mile*; (2) *2.6 miles*; or (3) *26 miles*?
8. Is a license with a radar endorsement necessary to permit one to change tubes in a radar receiver?
9. What frequency bands are used for shipboard radar? *10-6-3 centimeter bands*
10. Why are waveguides used instead of coaxial lines to carry energy between the transmitter and the radiator?

OTHER FOLKS WILL

There is only one method of meeting life's test;
Jes' keep on a strivin' an' hope for the best.
Don't give up the game an' retire in dismay
'Cause hammers are thrown when you'd like a
bouquet.

This world would be tiresome, we'd all get the blues
If all the folks in it held just the same views,
So finish your work, show the best of your skill;
Some folks won't like it, but other folks will.
If you're leadin' an army or building a fence,
Do the most that you kin with your own common
sense,

One small word of praise in this journey of tears
Outweighs in the balance 'gainst cart loads of sneers.
The plants that we're passin' as commonplace weeds
Oft prove to be jes' what some sufferer needs;
So keep on a-goin'; don't stay standin' still,
Some people won't like you, but other folks will.

* * * *

This little poem (I don't know who wrote it) appeals to me as being full of some very sound advice. I've found it helpful to read it over a time or two, whenever things all seem to be going wrong. I hope you'll like it too.

J. E. SMITH